

DOCUMENT RESUME

ED 241 781

CE 038 585

AUTHOR Sammataro, Diana
TITLE Lesson Plans for Beekeeping in the Philippines. Appropriate Technologies for Development. Reprint R-32.
INSTITUTION Peace Corps, Washington, DC. Information Collection and Exchange Div.
PUB DATE Sep 81
NOTE 69p.; Light type may not reproduce well. Prepared for Bee Training Seminar at National Rural Life Center, (Palapala, Cavite, Philippines, April 1978).
PUB TYPE Guides - Classroom Use - Guides (For Teachers) (052)
EDRS PRICE MF01/PC03 Plus Postage.
DESCRIPTORS Agricultural Education; *Agricultural Production; *Agricultural Skills; Agricultural Supplies; Agriculture; Entomology; Guidelines; *Learning Activities; Lesson Plans; Marketing; Postsecondary Education; Vocational Education; Voluntary Agencies; Volunteers; Volunteer Training
IDENTIFIERS *Beekeeping; Bees; Philippines

ABSTRACT

This set of lesson plans, prepared for use by Peace Corps volunteers in the Philippines, has been designed as a step-by-step guide to teaching beekeeping. Each of the eight lesson plans contained in the manual consists of an objective, time requirements, materials needed, and information about various aspects of beekeeping. Lessons are illustrated with line drawings. The lesson plans cover the following topics: construction of equipment necessary for beekeeping, requirements for obtaining bees, handling bees, colony management and seasonal manipulations, the bee colony and races of bees, problems in Philippine beekeeping, selection and rearing of queens for stock improvement, and marketing hive products. Plans for making various hives and equipment are included in the lesson plans. (KC)

* Reproductions supplied by EDRS are the best that can be made *
* from the original document. *

ED24178

Lesson Plans in Bookbinding

**U.S. DEPARTMENT OF EDUCATION
NATIONAL INSTITUTE OF EDUCATION
EDUCATIONAL RESOURCES INFORMATION
CENTER (ERIC)**

This document has been reproduced as received from the person or organization originating it.
Minor changes have been made to improve reproduction quality.

- Points of view or opinions stated in this document do not necessarily represent official NIE position or policy.

Peace Corps
INFORMATION COLLECTION & EXCHANGE
REPRINT H-32

ED03515



INFORMATION COLLECTION & EXCHANGE

Peace Corps' Information Collection & Exchange (ICE) was established so that the strategies and technologies developed by Peace Corps Volunteers, their co-workers, and their counterparts could be made available to the wide range of development organizations and individual workers who might find them useful. Training guides, curricula, lesson plans, project reports, manuals and other Peace Corps-generated materials developed in the field are collected and reviewed. Some are reprinted "as is"; others provide a source of field based information for the production of manuals or for research in particular program areas. Materials that you submit to the Information Collection & Exchange thus become part of the Peace Corps' larger contribution to development.

Information about ICE publications and services is available through:

Peace Corps
Information Collection & Exchange
Office of Programming & Training Coordination
806 Connecticut Avenue, N.W.
Washington, D.C. 20525
(202) 254-7386



Add your experience to the ICE Resource Center. Send materials that you've prepared so that we can share them with others working in the development field. Your technical insights serve as the basis for the generation of ICE manuals, reprints and resource packets, and also ensure that ICE is providing the most updated, innovative problem-solving techniques and information available to you and your fellow development workers.

Peace Corps

LESSON PLANS FOR BEEKEEPING IN THE PHILIPPINES

by .

Diana Sammataro

Prepared for Bee Training Seminar at
National Rural Life Center
Palapala, Cavite
Philippines
Director: Mr. Dick Fagan
April, 1978

Peace Corps
Information Collection and Exchange
Reprint R-32
September 1981

LESSON PLAN # 1

CONSTRUCTION OF EQUIPMENT NECESSARY FOR BEEKEEPING

Time: 1-1½ hours

Objectives: To show people interested in beekeeping how to make houses for bees. This is divided into two parts (1) simple hives from inexpensive parts and (2) wooden or box-type permanent dwellings.

Materials: For wooden hives only

lumber	wood chisel
nails	latex paint and brushes
hammer	T-square
saws	plane

I. Requirements for a good beehive:

1. easy to remove surplus honey.
2. easy for bees to store honey, especially after the surplus has been collected.
3. hive should last many seasons.
4. hive should be roomy enough, or expandable to accommodate growing bee populations and food storage.
5. the entrance should be large enough to allow easy passage of bees but small enough for the bees to defend their hive against pests.
6. hive should be durable enough to protect bees against hot, cold, rainy or dry weather.
7. hives should be convenient and comfortable for the beekeeper to work.
8. hives should be within the financial means of the beekeeper to work.
9. one hive should be on a scale and have a glass side to gauge the progress of all the hives without opening them up.

II. Simple Hives:

1. Hives without frames
 - clay pots (flower pots) or mud jars
 - log hives (sections of tree trunks with a natural hive inside) or hollowed out tree trunks

- mud-plastered wicker - "log" type hives
- hives in earthen embankments
- straw balled basket-type (skops), circular domes or squares
- hollow blocks
- old tires

2. Hives with frames

- bamboo or wicker work hives
- styrofoam boxes
- oil cans or drums
- kerosene can
- wooden crates
- cardboard boxes.
- wooden box hives or 'standard hives'

Advantages:

- materials basically free

Disadvantages:

- cumbersome hives if used without frames

III. Standard-Type Hives

1. Standardizing the wooden box hive has several advantages
 - easy to work and see bees
 - oldest known modern beehive
 - standard sizes allow for easy expansion and exchange (sale) of equipment
2. Disadvantages: expensive for rural farmers
 - requires equipment to construct
 - requires assembly time
3. Important Considerations for Making Wooden Hives

A. The Bee Space

-bees naturally build wax cells (comb) to fit their body size. The imported bee space is 5 cells / inch or $\frac{1}{4}$ " or (6.3 mm); the native bee is 6 cells / inch.

-if the space between frames, frames and walls, frames and tops or bottoms is smaller than the bee space, bees will fill it with bee glue or propolis.

-if the space is larger than the bee space, the bees will fill it with wax.

- B. Bee space in the simple hives is not important since the bees will fill in all the spaces naturally; no work by the beekeeper is required.
- C. Bee space in the wooden hives requires that the beekeeper make the equipment accurately, and space the frames properly within the hives. Otherwise, bees will fill up space with wax and beekeeper might have to cut frames out, injuring brood and losing honey.

IV. Other Equipment

1. The Smoker

-Smoke, used in moderate amounts, will cause the bees to eat honey; after they consume it, it is difficult for them to sting you on a full stomach. Some sort of smoking pot should be used, not a blazing torch of straw or bark; hot ash will burn bees, making them angry and the ash will dirty the honey.

A can with a metal blow tube on the top or bottom, or a can with a small bellows attached make good smokers. Use cotton or jute rags, rotten wood, wood shaving, dung or dry leaves; place a small bit of green grass on top to 'cool' the smoke and catch any ashes.

2. Veil and Hat

Bees instinctively aim for eyes when angry, so some sort of veil should protect your face and neck. The simplest veil can be a piece of mosquito netting sewn into a wide-brimmed hat. The netting should have some strings attached to the bottom to allow the loose ends to be tightened and tied.

A veil is generally not needed on weak or small hives, but it gives confidence to beginning beekeepers and keeps you from becoming distracted.

3. Hives Tool

This is a metal paint scraper that can be purchased or made from an old truck "leaf-spring" cut to 8 to 10 inches long. A sharp edge is maintained to help scrape away wax and bee glue or propolis from inside the hive.

4. Gloves:

Generally not needed unless you are moving a colony from a tree or house; gloves are worn by beginners for confidence. Actually, you will probably get stung more with gloves since overconfidence tends to make one clumsy and therefore you kill more bees, making them sting you.

Canvas or leather gloves are used and have long sleeves of cotton sewn on to the glove top to protect arms too.

5. Miscellaneous Equipment

- queen cages.
- solar wax melter
- honey extracting equipment
- comb foundation mill
- clothing (bee suit)
- observation hive
- uncapping knife (to cut honey)
- bee escape
- bee brush

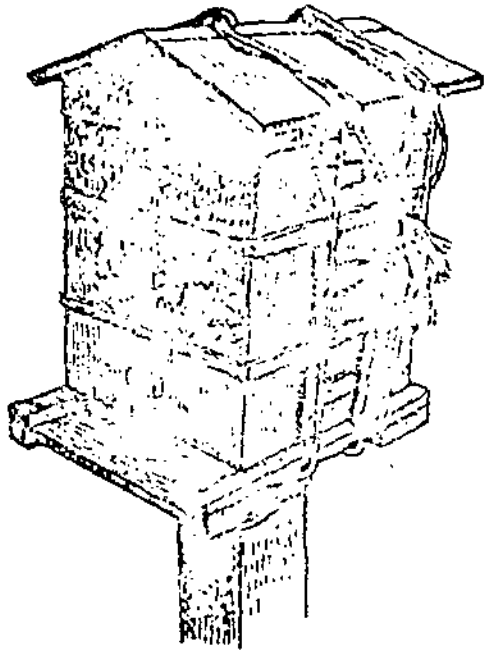

POLE STAND

Illustration #16

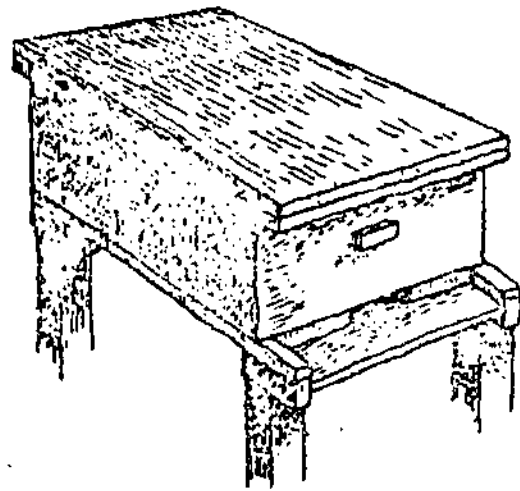

LEG STAND

Illustration #17

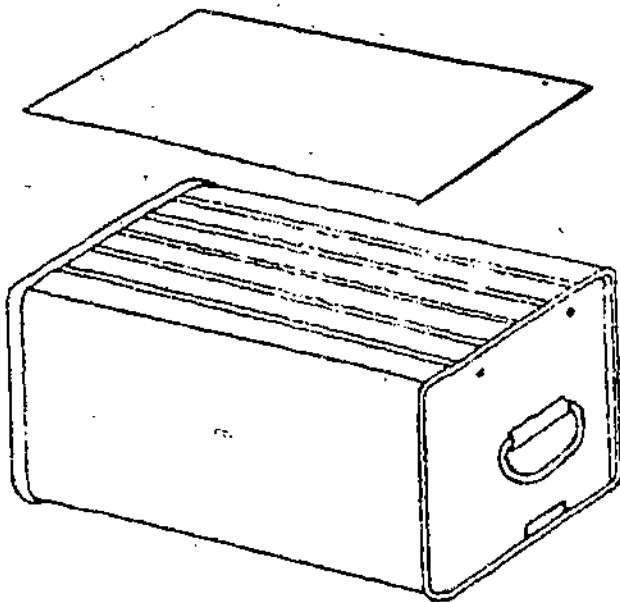

KEROSENE TIN HIVE

Illustration #18

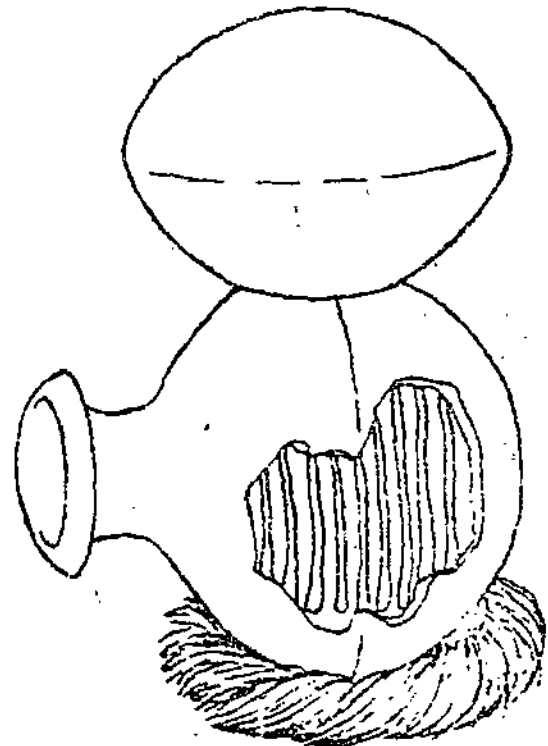

POT HIVE

Illustration #19

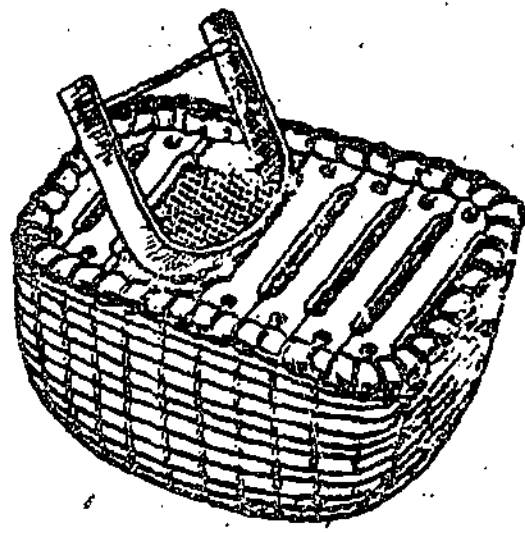
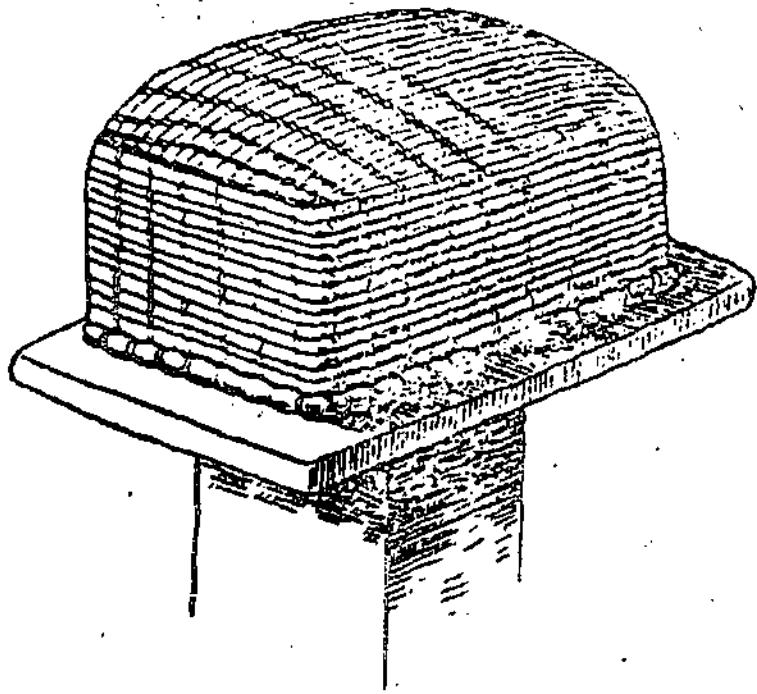

STRAW SKEP HIVE

Illustration #20

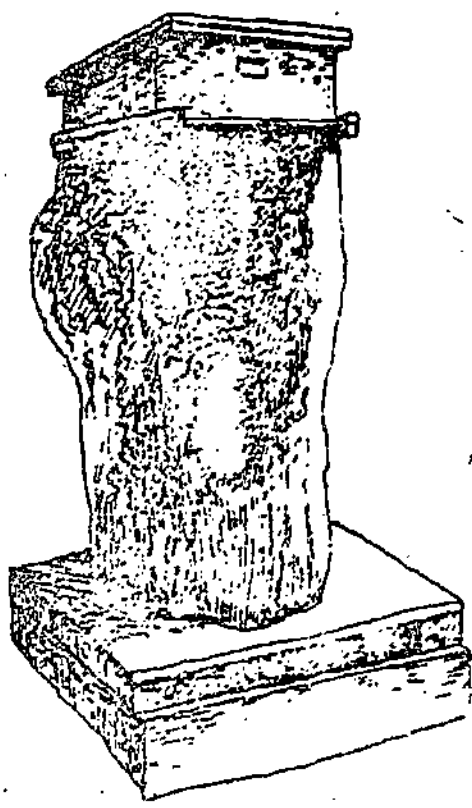

LOG HIVE

Illustration #21 10

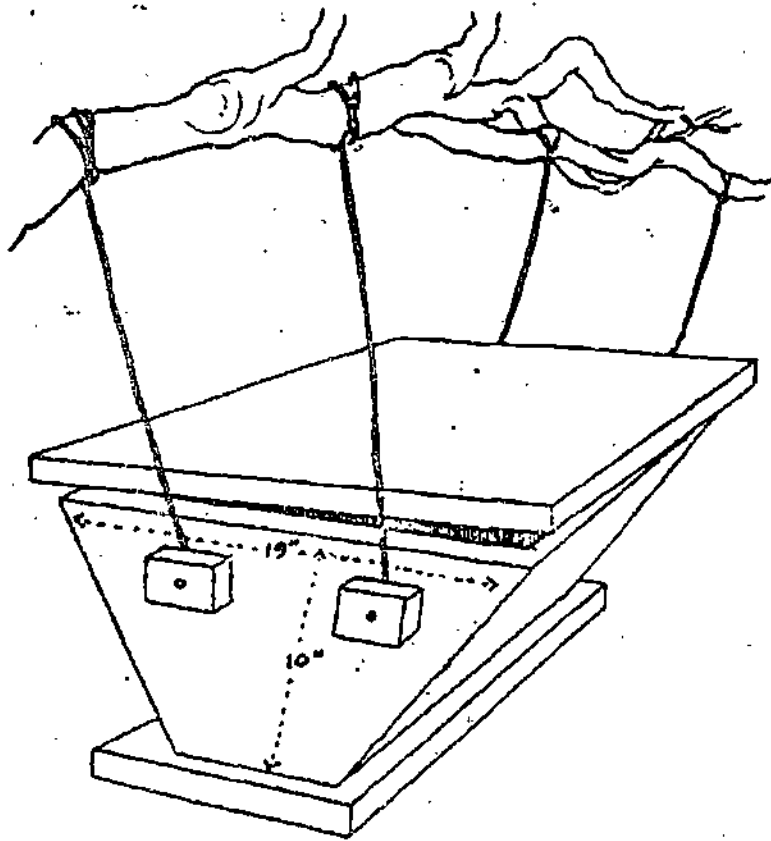

EAST AFRICAN TRANSITIONAL
Illustration #22

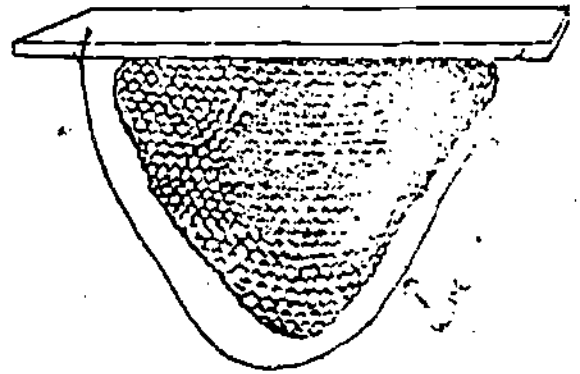

SIMPLE FRAME
Illustration #23

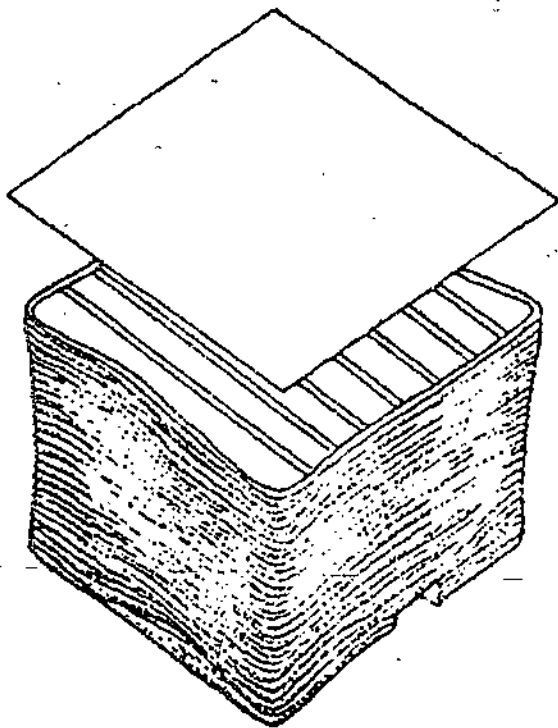

TRANSWOVEN HIVE

Illustration #24

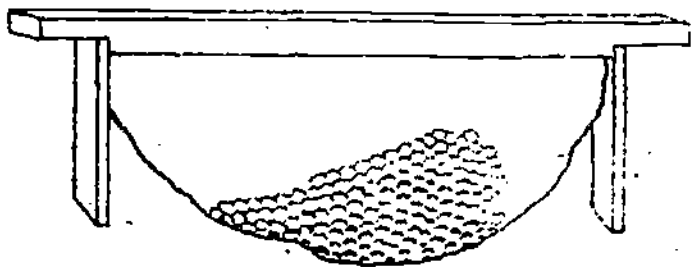

TRANSITIONAL FRAME

Illustration #25

Amex

COMPONENTS OF A BEE HIVE:

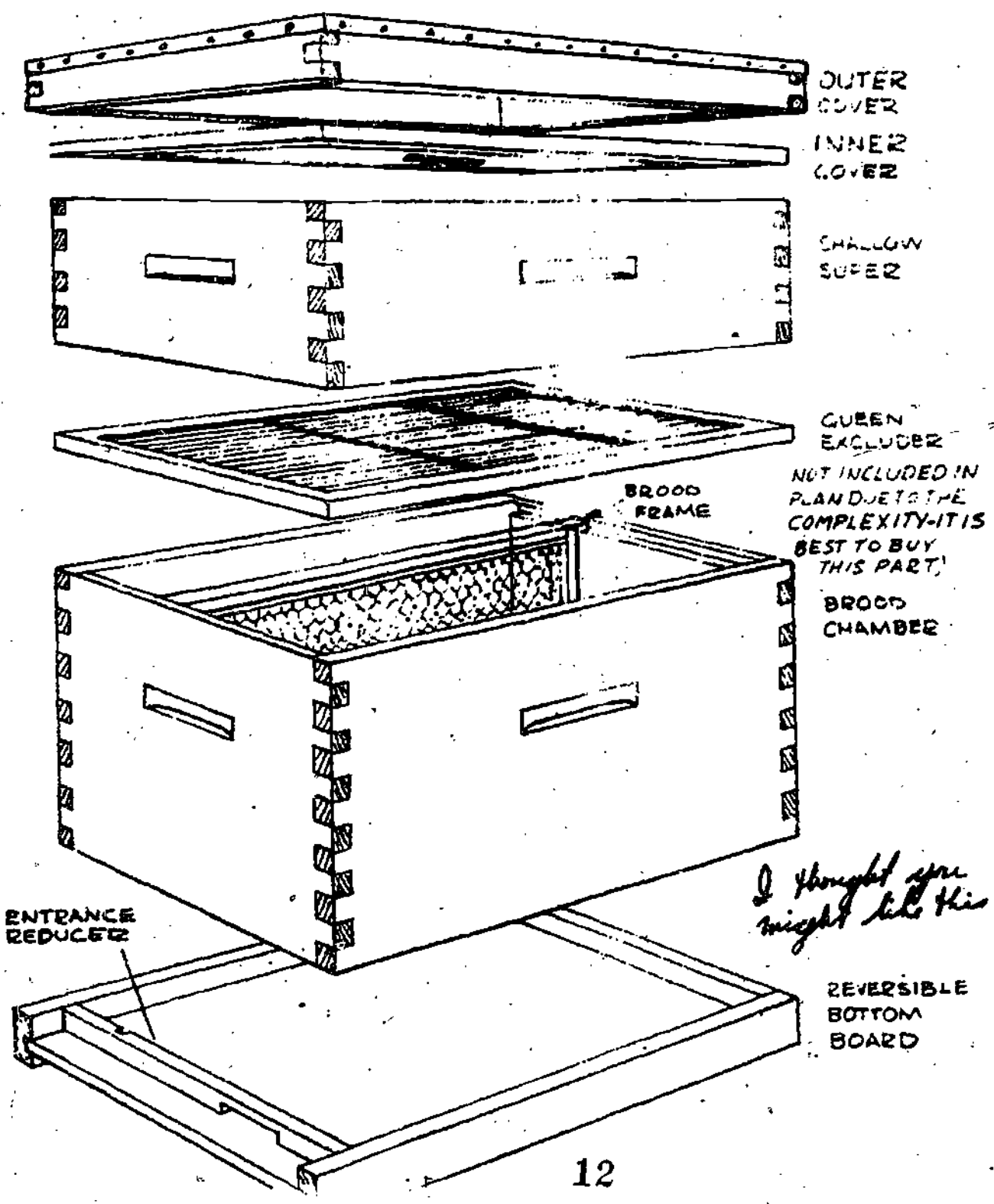

BELLOWS SMOKER

Illustration 927

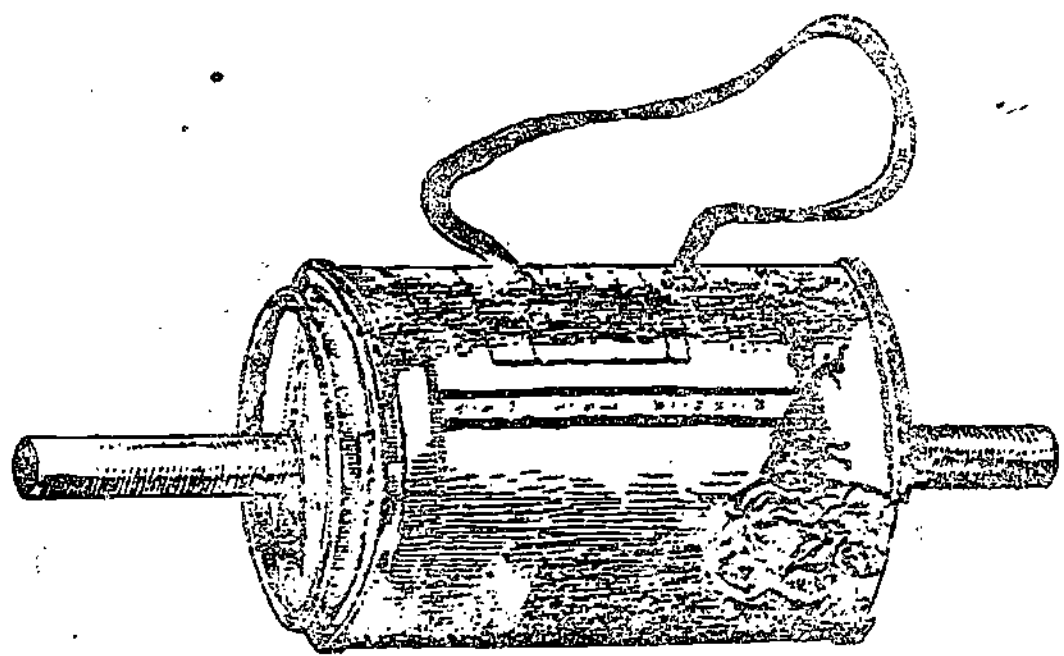

CAN SMOKER

Illustration 928

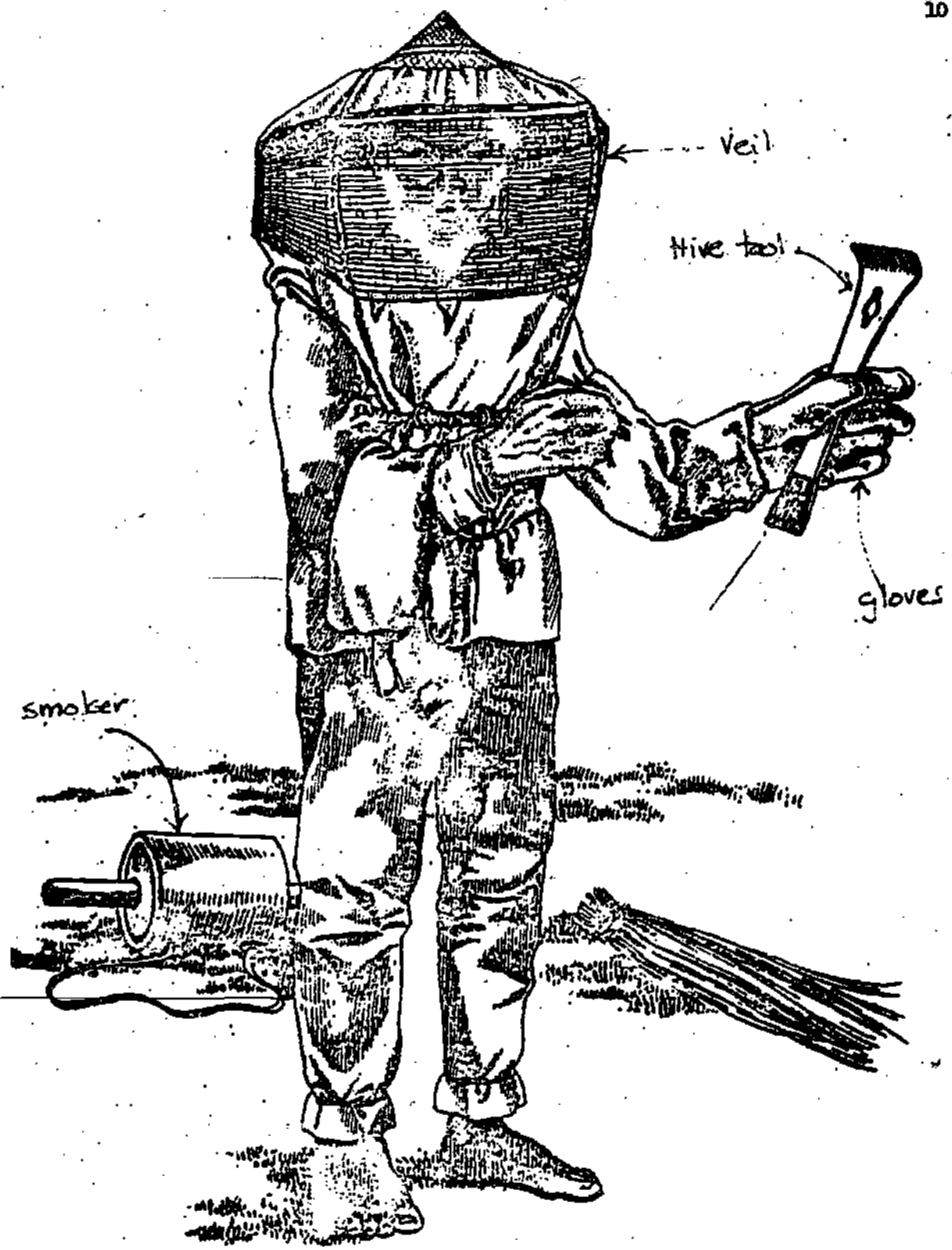

DRESSING FOR HONEYBEES

Illustration #26

LESSON PLAN # 2

REQUIREMENTS: FOR AND OBTAINING BEES

Time: 1-1½ hours

Materials: (slides)

Objectives: To help people who are interested in starting with bees to determine how much it will cost to obtain them, and where they can find bees; where they can locate the bees to take advantage of the honey potential and what bees require.

I. Requirements for having beehives

1. Selecting a site to put your bees (apilary)

- near fresh water supply not contaminated water.
- easy for beekeeper to reach and work
- near food sources for bees need flowering plants for nectar (honey), bee glue, and pollen (protein).
- on the top of a hill or high ground so water and air will drain away from hives.
- not on wet, swampy, lowland or in deep, humid woods, honey will not cure properly and bees could be subject to fungal diseases.
- facing east, south-east to catch early warmth of sun; entrances should be pointed away from monsoon winds.
- provide a wind-break to keep hives from being blown over in high winds and noontime shade during the dry hot seasons.
- away from floods and open fires.
- keep brush, vines, and weeds cleared away from hives; hives should be placed on a stand, (not directly on the ground) to keep out ants and other pests.
- nearby the beekeeper's house to discourage mischief-makers.
- away from areas heavily sprayed with insecticides.
- away from people, animals, etc.

L.P. # 2

II. Requirements for bees

1. What bees need to live

-Flowers supply both nectar and pollen for bees. Nectar is a liquid sugar solution that flowers manufacture. Since it contains mostly water, the bees must evaporate it to make honey which has about 18% water in it. The different flavors and colors of honey depend on the types of flowers the bees collected the nectar from. Honey is stored in the beewax cell.

Pollen comes from the male part of the flower; it is a powdery dust which comes off when rubbed by the bees. This pollen fertilizes the female part of the flower and produces the fruit, seed or vegetable. Bees collect this pollen by means of special hairs on its body, and return to the hive with it.

Pollen is packed into a wax cell, and then it is topped with honey, to preserve it; this is called bee bread. It is very important to have bee bread in the hive, for it means that the young bees and brood will have something to eat. A colony can use up to 100 pounds (50 kg.) of pollen in one season.

-Beewax is secreted by the young worker bees to make the honeycomb. All their honey, pollen, and brood (immature bees) are stored inside the wax comb cells. In order for bees to make wax, they need to eat large amounts of honey or sugar syrup and pollen. Some beekeepers place a sheet of beewax called foundation, in a frame, to help guide the bees as they build the cells.

-Water is important to bees. In hot, dry weather the interior of the hive could become overheated. If this occurred, the brood could 'cook' and the wax could begin to melt. Bees prevent this; they collect water and place it in the comb then fan it with their wings to evaporate the water.

L.P. # 2

This 'air-conditioning' cools the hive down. In very hot climates, the hives should be placed so they get noontime shade; painting the hives white will also help reflect sunlight.

-Bees use the sticky sap from trees and flower buds to make "bee glue" or propolis. This gummy material is collected to seal cracks and holes, and to water-proof the hive, it also kills micro-organisms that would otherwise invade and live in small cracks.

III. Obtaining Bees

1. Where to get bees

-A SWARM is a colony of bees clustered in the opening, not inside a hive box. They are looking for a new home. The Beekeeper can capture the swarm by placing it into a temporary or permanent hive.

Advantages:

-free
-common
-plentiful

Disadvantages:

-could be diseased or infested with pests
-could be in hard to get places
-could be of inferior stock

Cost: Free

-COLONIES IN TREES OR HOUSES, even earth embankments, are also free but are generally very hard for a beginner beekeeper to get intact. It involves destroying the house where the colony lives, or cutting down the tree, cutting the comb, and tying it to a frame and then getting the bees to stay inside the box. This should be attempted by someone already experienced in working with bees. You can also make bees swarm out of a trees or house by smoking and hitting the tree with a hammer continuously until the bees leave and cluster outside.

L.P. # 2

After they leave, they can be installed as a swarm.

Advantages:

- free
- plentiful
- extra wax and honey

Disadvantages:

- could get many stings
- difficult to get it intact
- queen could be killed
- bees could leave later

Cost: Free

-TRAPS can be placed to attract swarming colonies. The trap can be a frame of wax that is placed in a hollowed tree trunk, or in an empty hive, or in an earthen embankment hole. The frames should not contain any honey as this will attract ants and wax moths, and discourage bees.

Cost: Free

-BUYING bees from a beekeeper is another way to get started. Beekeepers can either sell you a full hive and all its equipment, or a nucleus hive with a small population of bees, and a laying queen, or a swarm (you provide the equipment) or a laying queen only.

Advantages:

- cared for by an experienced beekeeper
- all ages of bees and brood can be obtained
- easy to inquire from owner if there are any problems

Disadvantages:

- could have odd and old equipment that will need to be replaced
- queen could be old or of poor quality
- wax comb could have diseases or pests not at first evident.

-BUYING IMPORTED BEES as packages is another way to obtain bees. These bees are very expensive both to buy and to maintain and, while the returns might be higher, they will not perform well unless properly cared for.

L.P. # 2

Advantages:

- could produce more honey
- gentle and manageable
- do not swarm excessively

Disadvantages:

- subject to diseases and pests here
- requires more time, care and feeding
- could die from neglect

L.P. # 3

HANDLING BEES

Time: 1-1½ hours

Materials: Demonstration

-smoker, bee suit, veil, gloves,
etc.

Objectives: To demonstrate and inform beginner beekeepers how to handle bees and what to look for in a hive when examining bees.

I. Handling Bees

1. How to minimize stings

-work on days when bees are flying well since half of the foraging bees will normally be out; do not work when it is too windy, rainy or cold since all the bees will be at home.

-wear light-colored protective clothing and a veil. Make sure that ankles and wrists are closed in case bees start to crawl up. Beginning beekeepers will want to wear gloves for confidence; but gloves should not be used all the time. The best time to wear them is when transferring bees from a wild hive to a framed hive. Bee stings leave a scent on the gloves, so be sure to wash gloves periodically.

-use smoke lightly; this makes bees eat honey and they will be eating honey instead of stinging you.

-when working bees, use gentle, slow movement so the bees will not be alarmed.

L.P. # 3

Crushed bees cause alarm in the hive so move frames slowly.

-remain calm and work slowly, if you are nervous, or have an odor that alarms bees (hair tonic, horse smells) the bees will be more likely to sting you.

-if stung, scrape away sting barb; do not pull it out as this will inject you with more venom. Smoke the sting area as the venom leaves an odor "tag" which will excite other bees to sting you.

II. What to look for:

1. The Queen

-when you find her, be careful that she does not become crushed or drop on the ground. The queen is generally found around the warm broadnest or nearest the eggs and uncapped larvae.

2. Eggs

-when you look at a frame of uncapped larvae, check the frame carefully, and you might see eggs. If the hive has no eggs, or you cannot see brood, or the queen, you may consider the hive to be queenless. Requeen it by either giving it a queen cell, a new queen, or joining it to a "queen-right" hive.

3. Starvation

-when there is no honey or pollen in the hive, the bees may be more aggressive, and stop producing wax. When you do not see any stored honey or pollen in your hive, feed your bees white sugar and pollen substitute. If you are using the hive to make queens, feed the bees sugar syrup.

4. Good Brood Pattern/ Weak Hives

-when the queen lays eggs in every

L.P. # 3

empty cell so that the immature bees (larvae) fill up the comb, this is said to be a good laying queen showing a good brood pattern. Spotty egg-laying pattern, many drones (male bees) or a non-vigorous (slow) queen should be replaced. Weaker hives cannot defend themselves against pests (cockroaches, wax moths), or other robbing bees.

5. Swarm Preparation

-when the bees form numerous peanut-shaped wax cells, which contain immature queens, and the hive is quite populous (and may be crowded), the bees are probably starting swarm preparations. Swarming is a natural instinct; it divides the colony in half, and the old queen leaves the hive with half of the bees. The young queen meanwhile hatches, mates, and starts laying in the original hive. Unless you want to lose half your bees and honey these swarming preparations should be stopped.

6. Arrangement of Brood Nest and Honey Stores

-to optimize the proper temperature of the broodnest (97F) and in order to incubate the eggs, the broodnest (eggs, larvae) should be compact and not spread out. Frames of brood should be placed together, in one area of the hive. If the hive is populous, the honey will naturally be stored in the upper portions of the comb and of the broodnest. A frame of honey between frames of brood could prevent the queen from expanding the broodnest properly.

7. Surplus Honey

-bees instinctively store honey to eat during times of hardship or scaresness of food. Beekeepers try to make bees store more honey than they need and this surplus is what is harvested. To keep the queen from laying in the honey combs, surplus honey is usually found above the brood, in the upper portions of the hive. Some honey should be left on the hive at all times.

L.P. #3

Otherwise, bees will starve during dearth times, or leave the hive. If bees are starving and no food is available, white sugar syrup must be fed to keep bees from leaving.

8. Aggressiveness

-some hives are naturally more aggressive than others. This can be controlled by selection of the queens that are more gentle and requeening the aggressive hives with them. Hives that are too aggressive will sting often and may even swarm out while being worked. Aggressiveness may also be due to queenlessness, disease, or pest harassment.

9. Distress of Pests or Location

-if bees are placed in a damp, humid place, the honey will always be watery and could never 'cure' or ripen properly. Un-ripened honey will ferment eventually. On the other hand, hives that are in too hot a situation will be so busy bringing in water to cool the hive that no honey will ever be produced. Such stresses on the hive will weaken it and the colony may die, or leave. Weakened hives are subject to attack by such pests as mites and wax moths.

10. Queenlessness

-if you cannot find eggs, larvae, or capped brood or the queen and the hive is usually aggressive and restless, the hive may be queenless. Queenless conditions can be remedied by:

- providing new queens (virgin or laying)
- providing mature queen cells
- providing a frame of eggs
- joining it to a queenright hive

LESSON PLAN # 4

COLONY MANAGEMENT/SEASONAL MANIPULATIONS

Time: 1 hour

Material: slides

Objectives: To help beginning and experienced beekeepers to recognize a honeyflow and a dearth period in their area and to keep records by their hives.

I. Before the Honeyflow--Requirements of the Hive

1. The following conditions will help ensure a good crop of honey for the beekeeper.

- populous hive with many young bees, especially during the period just prior to the honeyflow (40,000 to 80,00 bees)
- hive should be free from pests and diseases
- colony should not be preparing to swarm
- hive should have ample room to store surplus honey
- weak hives can be helped by giving them frames, of young bees, capped brood or a new queen, or all of these. Keep all hives of equal strength, otherwise they will rob each other
- do not mix up the natural order of the frames in the broodnest; frames of honey can act as a barrier to the queen and if placed in the middle of the broodnest, could restrict the queen's laying activity.

2. Frames of pollen and honey should be kept above or on the sides of the broodnest; empty frames can be placed on the end of the broodnest to allow for growth. Frames of brood and pollen should not be placed in the honey supers as bees will fill up the empty cells with both honey and pollen and brood. You want the bees to fill up only honey in the honey supers.

L.P. # 4

3. Record Keeping

-beekeepers should keep accurate records on each hive or groups of hives in their apiary; especially noted are the hives that are significantly productive or weak. A note of when certain plants are blooming that coincide with the honeyflow will also help you to keep tract of the major honey plants in your area. Paper tacked inside the cover, or written on the hive body (not top) can be used. Permanent book or diary records are more trustworthy. Some things to record are:

- date worked
- age of queen
- colony strength and growth rate
- timely manipulations (swarm prevention)
- characteristics of hive (aggressive, gentle, productive, poor)
- swarming record-how often, when, why
- cash flow (how much money spent or earned)
- honey (how much (weight) taken off, per hive)
- hives lost (stolen, swarmed, wax moth, diseases)

II. During the Honeyflow

1. At certain times of the year, when most of the flowers from fruits, vegetables and weeds are blooming, bees will often start bringing in a surplus of honey. This is called the honey-flow period and can be recognized by:
 - lots of wax production (white new wax)
 - populous hives, working very hard
 - honey being stored (uncapped and capped)
 - honey with many white tops appearing in the comb
2. Swarming behavior usually comes before the honey-flow period so, if you do not wish to lose a lot of honey (through the lack of bees because they left with the swarm), discourage swarm preparations by:
 - out out queen cells (if they are numerous and hive is populous with a laying queen)

L.P. # 4

- supply more space to the hive; either adding frames or an extra hive body (super)
 - inspect the hive periodically (once/week) to ascertain swarming preparations.
 - make sure hive is not overheated (keep in shady but breezy spot)
 - provide a young queen
3. During the honeyflow, the hive should not be disturbed too much. If you go through the broodnest, the organizational structure of the colony can be destroyed. When bees are disorganized, they will probably not bring in as much honey as they would have normally for that day. The only inspection you should be making during the honeyflow is whether or not the bees have enough room to store honey, (this does not apply of course, to weak or diseased hives)
 4. Examine the honey frames before removing them from the hive. Most of the honey should be sealed with a wax top or 'capping'. If the honey has not been properly cured (all the water evaporated) it will begin to ferment and spoil
 5. Remove the honey frames early in the morning before the bees start bringing in new nectar. Take off the sealed honey frames and cut the comb. The frames should be over 75% capped honey. Cut the comb or scrape off the honey to the mid-rib (bottom) of the cell and leave a "foundation" for them to rebuild. If a hot spoon or knife is used, the honey will come off much easier.

III. During the Dearth or Starvation Periods

1. Dearth periods are times when no honey or pollen is being brought into the hive. The signs of dearth, which could lead to starvation if all the honey was removed, are:
 - no honey in cells
 - no pollen stored or brought in
 - wax production cut off, foundation chewed

L.P. # 4

- no brood, or brood rearing limited
- all stages of drones (brood and adults) are pulled out and dumped out of the hive during severe dearth
- robbing activity increased, hives aggressive
- honey stored in brood cells since there is no new brood, once a small honey flow starts.

2. Dearth times are seasonal, after the major flowering period is over, during rainy, cold, dry or hot seasons; the beekeeper should;
- make sure bees have enough food (honey/pollen) at all times; take off only a SURPLUS of honey; leave 20-60 lbs. depending on the hive strength and duration of the dearth time.
 - make periodic inspections so that hives will not get too weak
 - feed bees if they are starving with sugar (white) or white sugar syrup.
 - remove excess frames (that hives will not get too weak
 - feed bees if they are starving with sugar (white) or white sugar syrup.
 - remove excess frames (that are empty) and supers; otherwise, too much heat could be lost from the broodnest, or the wax moth and other pests, could invade the empty spaces.



COLLECTING A SWARM

LESSON PLAN # 5

THE BEE COLONY AND RACES OF BEES

Time: 1- $\frac{1}{2}$ hours

Material: slide, charts, pictures

Objectives: To help beekeepers understand the roles that the individual members of a colony have on the colony as a whole, and to inform them of the various kinds of bees.

I. The Colony

1. A colony of honey bees will have a fertile female or queen, many male bees (or drones) and many thousand infertile females or workers. These classes of bees together form a unit or collection of individuals which, if separated from the colony unit would shortly die.

2. The Queen

-usually there is only one queen to a colony, and her sole duty is to lay eggs. She resembles a worker but with a much longer abdomen and a dark shiny thorax or back. The queen is fed almost entirely on a food secreted by the young worker bees called royal jelly which is rich in proteins. The number of eggs she lays, therefore, will depend on the amount and kind of food she is fed, the number of young workers to incubate the eggs and the environmental conditions. She lays eggs that may hatch into drones (infertile eggs), workers or new queens (fertile eggs).

The (European) queen hatches from a special peanut-shaped cell in 16 days. After emerging, the queen will take her mating flight 5-10 days later, where she will mate with several drones. If a virgin queen does not mate after two weeks, she will probably be a poor, drone-laying queen. Queens can live several years.

L.P. # 5

The queen has a special odor or substances which keeps the colony unit together. If the queen is removed, the worker bees will start to make preparations to make a new queen. Queenless hives lack organization and could be more aggressive than queen right hives.

3. The Drone

-The drone is a larger and heavy looking bee, with very large eyes and chunky abdomen. His sole function is to mate with new queens; he does no work and cannot sting. Normally, high drone populations are only tolerated when ample food is coming into the hive; when the honey season is over, drones are evicted from the hive, to die.

-European drones take the longest to emerge, up to 24 days. If you are using the imported bee (European), drone production should be encouraged, since there would be few drones available to mate with virgin queens. When using the native bee, drone production should be limited.

4. The Worker

-There are anywhere from 5,000 to 75,000 workers in one colony. They are called workers because they do the house and foraging work required for colony survival. The task of the workers, includes feeding larvae (undeveloped bees), tending brood (immature bees), feeding and tending the queen, guarding the hive, evaporating nectar to make honey, packing pollen, and maintaining broodnest temperatures. As the workers age (3 weeks or so) they begin to leave the hive to forage for food. Once a scouting forager locates a food source, the distance and direction of the food is communicated by a combination of dancing, scent and sounds. They are foragers only for about another 3 weeks before they die.

It takes 21 days for a (European) worker to emerge. They have special legs equipped to pack the loose pollen grains, and have special glands to secrete wax, stinging venom, and royal jelly. Workers collect nectar, pollen, water and propolis or glue, returning to their hive with it. See attached diagram.

L.P. # 5

II. Races of bees and bee relatives.

1. Wasps (Vespidae)

-wasps are not bees but are often mistaken for bees by many people. Wasps make their homes with paper-like material or mud. While some do sting aggressively, wasps are beneficial pollinators and insect controllers, being parasitic and predacious on many insect pests. Unfortunately, some wasps also prey on honey bees.

2. Bumble Bees and Carpenter Bee (Bombidae and Xylocopidae)

-these are large, hairy bees varying in color from blue-black to black and yellow stripes. They live in the ground, grass hatch or dry wood. Although they do not produce a significant amount of honey, they are valuable as pollinators of many fruits, seeds or vegetable crops.

3. Stingless Bees (etc.)

-There are many races of other social bees, (living in hives) and solitary bees, (living alone) that are important pollinators. The stingless bees (Trigona and Melipona) will store honey in nests, but it is generally too little to attract most beekeepers. Since they are beneficial, colonies should not be destroyed.

4. Honey Bee (Apis)

a) The Rock or Giant Bee (Apis dorsata)

Rock bees are nomadic, rarely staying long in one place. When they fly, farmers in the field report they sound like a passing airplane. The colony consists of a single comb hanging from a branch of a tree, roof or abandoned ceilings. The worker is light brown while the queen is darker and longer; the drone is black and about the size of a worker.

Rock bees produce good honey and wax, working longer hours sometimes than other honey bees. Honey can be harvested without destroying the hive,

L.P. # 5

two to three times a year when smoke and proper precautions are taken. Yields of up to 35 kg. during a year have been recorded. Smoke seems to control their volatile temper and while they will not live inside a hive box, groups of colonies can be raised together.

b) The Little Bee (Apis florea)

These bees are smallest of the honey bees, and are also nomadic. They make small, hand sized combs in tree branches, caves, bushes, empty boxes, or ceilings. The workers are orange with black and white stripes. The queen is golden brown and the drones black with grey hair. Again, they do not produce much honey (0.5 to 1 kg.) but some countries are finding them a gentle, and manageable honey bee.

c) The Indian Bee (Apis indica cerana)

This bee is used in India and other countries as the main Asian Honey Bee. It is easily housed in boxes, tins, jars and wall recesses. While there are regional varieties, the potential for this bee in the Philippines is just beginning to be realized. The wilder, swarm-prone strains can be bred for more domestic qualities.

On the average, colonies can yield 3-5 kg., although improved strains have been reported to produce 18 kg. or more. It can be a good producer, gentle and relatively non-swarming, but are less predictable, can steal food from weaker hives aggressively, and seem to have little defense against wax-moth and other pests that enter the hive. They use little propolis or bee glue, which might account for these invasions.

d) The European Bee (Apis mellifera)

This bee, originally from Europe, has been naturalized in many parts of the world, including North and South America. It is a very good honey producer,

L.P. # 5

averaging 45 to 180 kg. in good honey-yielding areas. It is similar to the Indian bee in its habits, making its home in enclosures like hollow trees, caves, and boxes. It is well adapted to life in moveable frame hives. Importation of the European bee should be restricted to well-equipped, responsible agencies with quarantine arrangements. To avoid the importation of diseases and pests common in the U.S. and Europe, which could be passed to native bees, private beekeepers should consider improving native bees first.

EXTERNAL ANATOMY OF A WORKER HONEY BEE

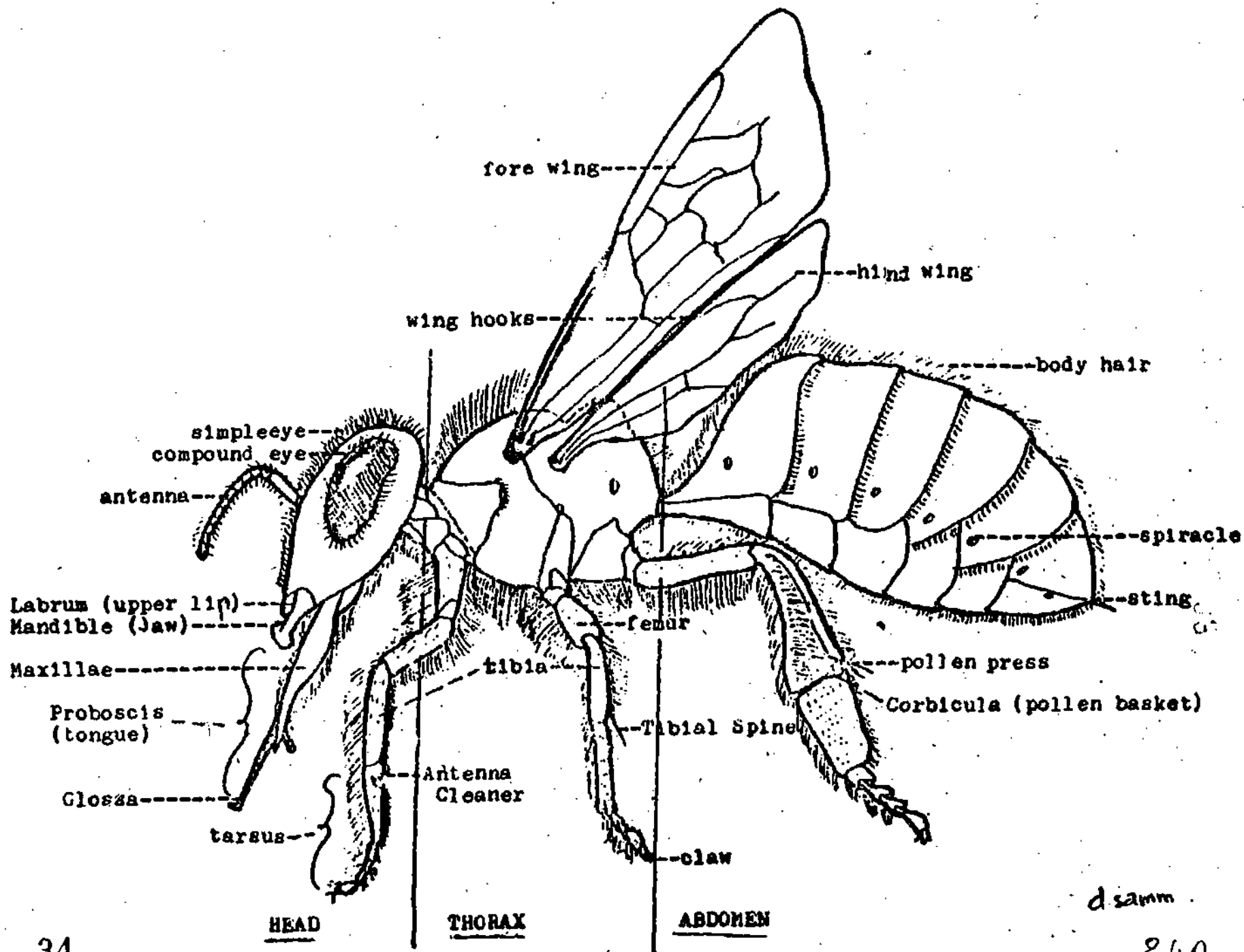

LESSON PLAN # 6

PROBLEMS IN PHILIPPINE BEEKEEPING

Time: 1-hour

Materials: Collection, demonstration

Objectives: To acquaint beekeepers or beginners with the problems that exist in the Philippines and how to control them or minimize damage caused by them.

I. Pests

1. Ants: can invade hives, eating brood, honey, pollen and bees; eventually the hive will either be so weakened or aggressive, that they will abscond (or leave)

-control: grease hive stands with auto grease and lime ground at base of stands. Never set hives directly on the ground.

2. Wasps and other predacious insects: will catch bees on the wing and take them away to be eaten. They are not a real threat except to weak hives. Traps can be devised to catch the black wasps as they hover in front of the hives;

-control: maintain a strong hive or hire someone to catch the wasps as they hover

3. Lizards and Toads: will also eat bees but generally, if the hives are on a stand, the loss is minimal.

4. Beetles and Cockroaches: can infest a hive, especially when being fed pollen supplement or substitute. A strong hive will evict these intruders, otherwise remove debris in hive bottom that they might be living in, and keep entrance small (esp. true for the native bee).

5. Wax moth:

This is a moth which lays eggs in the comb and upon hatching, the larvae can cause much damage to the comb and brood,

L.P. # 6

by borrowing, spinning silk tunnels, and damaging wax.

-control: strong hives can usually combat this pest but when it starts taking hold, removal of the infested comb and cocoons is imperative, otherwise the bees will leave the hive, Comb can be stored in paradichlorobenzene (moth ball) crystals, if kept in a plastic bag or other enclosure, and aired out a day before returning treated comb to bees. Combs can also be put in freezing temperature for several hours, especially if wax contains honey and pollen.

6. Birds: sometimes, droves of swifts have been reported (Chaetura dubia - Spine-tailed swift) to eat 100 bees each in one day.

-control: about the only methods of control seems to be netting the birds or moving hives to other location.

7. Mites: two types of external mites are of vital importance to beekeeping here. The two (Varroa jacobsoni and Tropilaelaps clareae) are serious pests that can destroy a hive. Drones and workers with deformed wings, dead pupae in the cells and the mites on bees should be checked. It is believed that all species of Bees have mites here.

-control: is especially important for the European bees, and perhaps for native bees too. Colony strength appears to be a factor, the stronger hives may be better able to control this pest. Other chemical controls are also available, at great cost, since many have to be imported. Here are some:

-:Phenothiazine PTZ (worming tablets) 5% dissolved in 95% pure alcohol, applied onto cardboard strips and burned in the smoker, or placed under the hive sprinkled on a cardboard

L.P. # 6

bottom, at night, left for 2 days.

:Folbax strips prepared paper strips can be purchased, burning 2-3 strips per colony.

:Sineacar (from Romania) is a powder, sprinkled on bees once per week for three weeks.

II. Other Problems:

1. Drones: if imported bees are used, the lack of drones from these bees will make it hard to mate virgin queens. Hives that are strong, well fed, with a drone-laying or a fertile queen, will supply the best drones to supply your yard. Drones of the native bee have been reported to fly with the virgin imported queens, but is not a fertile cross.
2. Robbing: weak hives are subject to attack by robber bees from other hives (imported and native) as well as other insects. Where at all possible, hives should be kept of equal strength, and races of bees should be kept separate. Mites could be carried by robbing bees.
3. Insecticides: there seems to be indiscriminate use of harsh insecticides by farmers here. Since bees are susceptible to most of these, efforts should be made to educate farmers that bees are not injuring their plants, but in fact will increase their yields if they let the bees work them.

If insecticides are used, spraying should be done in late afternoon to evening hours, to minimize bee losses. Hives should be covered or moved away if spraying is closer than two miles. Less toxic chemicals (see attached list) should be used whenever possible.

4. Feeding bees
During dearth times if bees are robbed of all their honey, both a pollen and nectar substitute should be supplied

L.P. # 6

if the hives are to remain strong and not abscond. The most refined sugar or sugar syrup should be used, although experiments are lacking on the effects of feeding second class sugar in the tropics. Molasses should never be fed, however, as this will give the bees dysentery.

Other sugary substances can be tried, buko milk, or cane syrup.

Pollen is also important for brood rearing. Imported, brewers yeast and soy flour is the usual pollen substitute.

RELATIVE TOXICITY OF PESTICIDES TO HONEY BEES AS DETERMINED
BY LABORATORY AND FIELD TESTS IN CALIFORNIA (1950 - 1975)

GROUP I - HIGHLY TOXIC: Severe losses may be expected if these pesticides are used when bees are present at treatment time or within a day thereafter, except as indicated by footnotes.

Afugen [®] (pyrazophos)	DDVP [®] 2/ (dichlorvos)	Furadan [®] 2/ 5/ (carbofuran)	Mesuroi [®] (methiocarb)	Sumichion [®] (fenitrothion)
aldrin 2/	Dibrom [®] 2/ 3/ (naled)	Gardona [®] 1/ 2/ (tetrachlorvinphos)	Methyl parathion 1/ 2/	Supracide [®] 2/ (methidathion)
arsenicals 1/ 2/	De-Fend [®] 2/ (dimethoate)	Guthion [®] 1/ 2/ (azinphos-methyl)	Mopitor [®] 2/ (methamidophos)	Tameron [®] 2/ (methamidophos)
Azodrin [®] 1/ 2/ (monocrotophos)	diazinon 2/ (Spectracide)	heptachlor 1/ 2/	Nemacur P [®] (phenamiphos)	Temik [®] 1/ 2/ 5/ 7/ (aldicarb)
Baygon [®] 2/ (propoxur)	dieldrin 1/ 2/	Imidan [®] 2/	Nudrin [®] 2/ 5/ (methomyl)	tepp 1/ 2/ 3/
Baytex [®] 2/ (fenthion)	Dimecron [®] 2/ (phosphamidon)	Lannare [®] 2/ 5/ (methomyl)	Orthene [®] 2/ (acephate)	Vapona [®] 2/ (dichlorvos)
BHC 2/	Dursban [®] 2/ (chlorpyrifos)	lindane 2/	parathion 1/ 2/	Zectran [®] 2/ (meascarbate)
Bidrin [®] 1/ 2/ (dicrotophos)	EPN 1/ 2/	Lorsban [®] 2/ (chlorpyrifos)	Phosdrin [®] 1/ 2/ 3/ (mevinphos)	
Cygon [®] 2/ (dimethoate)	Ethyl Guthion [®] (azinphos-ethyl)	malathion 2/ 4/	phosphamidon 2/	
Cythion [®] 2/ 4/ (malathion)	Fenophos [®] (fenaphur)	Metacil [®] (aminocarb)	resmethrin	
Dasanit [®] 5/ (fensulfothion)			Sevin [®] 2/ (carbaryl)	
			Spectracide [®] 2/	

GROUP II - MODERATELY TOXIC: These can be used around bees if dosage, timing, and method of application are correct, but should not be applied directly on bees in the field or at the colonies.

Abate [®] 2/ (temephos)	Ciodrin [®] (crotoxyphos)	andrin 1/ 2/	Perthane [®]	Trithion [®] 2/ (carbophenothion)
Agritox [®] (trichloronate)	Counter [®]	Korlan [®] (ronnel)	Pyramat [®]	Vydate [®] 2/ (oxanyl)
Banol [®] (carbanolate)	DDT 1/ 2/ 10/	Metasystox R [®] 2/ (oxydemeton-methyl)	Systox [®] 1/ 2/ (deneton)	Zolone [®] (phosolone)
Carzol [®] 2/ (formetanate)	Dechlorane [®] (mirex)	mirex-(Dechlorane)	Thimet [®] 1/ 2/ 6/ (phorate)	
chlordana 2/	Di-Syaton [®] 1/ 6/ (disulfoton)	Mocap [®] (ethoprop)	*Thiodan [®] 2/ (endosulfan)	

**Relative Toxicity of Pesticides To Honey Bees As Determined
By Laboratory and Field Tests in California (1970 - 1975)**
(Continued)

36

GROUP III - RELATIVELY HARMFUL: These can be used around bees with a minimum of injury.

INSECTICIDES & ACARACIDES

Acaraben[®]
(chlorobenzilate)

allethrin

Alcofide[®]
(methoprene)

Acetia thuringiensis
(Accoate[®], Biotrol[®],
Dipel[®], Thuricide[®])

Bixolan[®]
(chlorvinphos)

Chloroparacide[®]
(chlorobenzilate)

cryolite^{2/}

Dalnav[®] (dioxathion)

Dassia[®] (dinobutox)

Dhailin[®]

DNOCP

Dylax[®] 2/
(trichlorfon)

Ethodan[®] (ethion)

Ethrel[®] (ethaphon)

Kradax[®]
(chinoschlorat)

Fusial[®]
(chloridifos)

Galecron[®]
(chloridifos)

*Melittobis poly-
hedrae virus*

Kalthan[®] 2/ (dicofol)

Kapene[®] (chlordecone)

methoxychlor 2/
(Marslate[®])

Morastan[®]
(oxythioquinax)

Morocida[®] (binapacryl)

Murvaeco[®] (fenoxon)

Managon[®] 2/ (dibromo-
chloropropane)

Mootras[®] 2/
nicotina 2/

Omite[®] (propargito)

Pumax[®]

Ylictran[®]

pyrethrum (natural)

rotenone 2/

ryania 2/

sabadilla 2/

Saghee[®] (manacor)

Tedion[®] (tetradifos)

tetran

Torax[®] (dialifor)

toxaphene 1/ 2/

FUNGICIDES

Arasac[®] (thiram)

Bealate[®] (benconyl)

bordeaux mixture 2/

Bravo[®]
(chlorothalonil)

captan

copper oxychloride
sulfate

copper 8-quinolinate

copper sulfate

cupric hydronide
(Locide[®])

cuprous oxide

Cyprax[®] (dodine)

Dalan[®] (diathionon)

Dazon[®] 2/ (fenamiphos)

Difolatan[®] (captafol)

Dithane D-14 (nabam)

Dithane M-22[®] (maneb)

Dithane M-45
(mancozeb)

Dithane Z-78 (zineb)

Do-Tex[®]
(fentia hydronide)

Dyrene[®] (amilastat)

Kradax[®] (thioquinox)

ferbam

folpet

Glycoide[®] (glydine)

Karathane[®] (dinocrop)

Nylone[®] (dasmet)

Phygon[®] (dichlora)

Plantvax[®]
(oxycarboxin)

Polyram[®] (acrisol)

omifur 2/

Vitavax[®] (carboxin)

Exorate[®] (siram)

**HERBICIDES, DEPOLLANTS
& DESICCANTS**

Aatran[®] (atrazine)

Almap[®] (neptalen)

Amiben[®] (chloramben)

antrol

Asmate[®] (AMS)

Avonox[®] (difenzoquat)

Balan[®] (bonafin)

Benval[®] (dicamba)

Betanal[®]
(phosmetiphos)

Betanal AM[®]
(desmediphos)

Bledax[®] (cyanazine)

canodylic acid 1/

Ciporol[®] (prometryne)

Cacoron[®]
(dichlorbenil)

Chloro EPC[®]
(chloroxypropam)

Ceserut[®]
(flumetsulam)

2,4-D 1/ 2/

Desoxate[®] 1/ (DEMA)

dalapon

2,4-DB 1/

2,4-DB 1/
(dichlorprop)

DEP[®] 2/

diquat 2/ 2/
(dinitrobutylphenyl)

Endothal[®] (endothall)

Eptam[®] (EPTC)

Polax[®] 1/

Herbisan[®] (RID)

Hyvar[®] (bromacil)

Igran[®] (terbutrya)

IPC[®] (propham)

Karam[®] (diazon)

Kerb[®] (promide)

Lasco[®] (alachlor)

Leron[®] (limaron)

Maleran[®]
(chlorbromuron)

WCPA 1/

Merhar[®] 1/ (DGM)

Milgard[®]
(propazine)

Modom[®] (bifenox)

Naarlan[®]
(isopropalin)

paraquat 1/ 2/

Planavin[®] (nitralin)

Primital[®] (prometon)

Profuron[®]
(flucrodifen)

Princap[®] (simazine)

Proba[®] (methasole)

Ramrod[®] (propachlor)

Ramox[®] (CDA)

Ronstar[®] (oxadiazon)

Samcap[®] (dipropetryn)

Sencor[®] (metribuzin)

silver 1/ (2,4,5-TP)

Sinbar[®] (terbacil)

Surflan[®] (oryzalin)

Suren[®] (butylate)

2,4,5-T 1/ 2/

Talvar[®] (monuron)

Tenoran[®]
(chloroxuron)

TOC[®] (nitrofen)

Tordon[®] (picloram)

Triflan[®]
(trifluralin)

Tryban[®] 1/
(2,3,6-TBA)

Vegadox[®] (CGC)

40

BEST COPY AVAILABLE

Relative Toxicity of Pesticides In Honey Bees as Determined
By Laboratory And Field Tests In California (1950 - 1979)
(Continued from page 36)

- 1/ California state regulation requires permits for most uses of these chemicals; also for 2,4-D and 2,4,5-T as weed treatments but not as hormone sprays on citrus.
 - 2/ These chemicals have been laboratory tested and field tested mainly on alfalfa, citrus, cotton, ladino clover, milo and sweet corn; all others are laboratory tested only.
 - 3/ Dibrom[®], Phosdrin[®] and tepp have such short residual activity that they kill only bees contacted at treatment time or shortly thereafter. These chemicals usually are safe to use when bees are not in flight; they are not safe to use around colonies.
 - 4/ Malathion has been used on thousands of acres of blooming alfalfa without serious loss of bees. However, occasional heavy losses have occurred, particularly under high temperature conditions. If applied to alfalfa in bloom, it should be only as a spray, and treatment should be made during the night or early in the morning when bees are not foraging in the field. Undiluted technical malathion spray should not be used around bees.
 - 5/ Kemtocid[®].
 - 6/ Di-Syston[®] and other systemic pesticides used as weed treatments have not caused bee losses.
 - 7/ Tenik[®], although highly toxic to bees as a contact poison, is used only in granular form and extensive field usage has not caused bee losses.
 - 8/ Befelliant
 - 9/ Beesectant
 - 10/ DDT has been temporarily withdrawn from most uses in the U.S.A.
- Registered trade name.

BEST COPY AVAILABLE

LESSON PLAN # 7

SELECTION AND REARING OF QUEENS FOR STOCK IMPROVEMENT

Time: 1-hour

Materials: Demonstration

Objective: To help beekeepers improve their honey yields, by selecting high-producing, low swarming queens.

I. Primary Selection Objectives

1. Fertility of Queen:
 - queen should exhibit good egg-laying capabilities, at the time of year when workers are needed, when there is available food, not during dearth times.
2. Industry and Productivity
 - workers should bring in the best honey crop possible, they should have large honey crops and strong legs to bring back large baskets of pollen.
3. Disease or Pest Resistance
 - those bees better able to fend off pests and disease should be selected.
4. Lowered Swarming Instinct
 - colonies that swarm or abscond frequently, should not be used to rear queens.
5. Good temper, gentle
 - propagate those queens from calm, gentle hives, where the bees will not leave the hive due to disturbances by beekeepers or others.

II. Secondary Selection Objectives

1. Long life of queen and worker
2. Long Foraging range:
 - workers should fly greater distances to gather nectar in difficult areas; also those working earlier in the morning and later in the evening, putting on more honey should be selected as breeders.

L.P. # 7

3. Defensive attitude against pests;
-keep hives able to keep ants, wasps, cockroaches, etc. out of hive.
4. Hardiness:
-those hives that come through dry, cold, wet or dearth seasons with populous colonies should be used.
5. Good growth
-hives that bear brood well even without feeding should be selected, (nurse bees tend larvae well).
6. Comb Building
-readiness to build comb and build it in frames should be selected.
7. Good orientation
-bees that are able to find their way back to the hive without drifting to other hives, should be selected.
8. Cleanliness
-hives that keep debris off the bottom board are desirable

III. Rearing Queens

A. Factors for queen cell production

1. Young larvae, less than two days old; all larvae receive royal jelly until they are two days old; those larvae that are to become workers, are not fed royal jelly after two days, but are fed a mixture of pollen and nectar. Only larvae that are to be queens receive the royal jelly as their sole diet.
2. Strong, populous hives with many young bees that may be ready to swarm provide conditions that are optimum for rearing queens. Food, both pollen and nectar, must be abundant; if not, supplemental food should be fed to the bees in the form of white sugar syrup and pollen supplement.

L.P. # 7

3. Drones are produced during these conditions as well, and it is important that the food and populous conditions are maintained if the drone populations is to be encouraged. Drones mate with the virgin queens.

B. Natural Rearing of Queens: Queen cells are made by worker bees under the following conditions in the hive:

a) swarm cells: When the hive is crowded and the bees are getting ready to swarm, they make queen cells. Select these queen cells carefully, so that the swarming instinct is not bred into the new queens.

b) supersedeure cells: When the hive replaces the old queen by making new queen cells. Conditions for replacing the old queen are when the queen is old, failing, diseased or poorly mated. If hive is populous, these cells can be used. Queens from these cells, however, can be inferior.

queenless or emergency conditions: When the hive has to make a new queen because the original queen is gone. If the hive is again strong and well-fed, these queens can be used. To make the hive build queen cells, you can

- 1) remove or kill original queen
- 2) split hive equally, giving each half pollen, honey and bees. Give one half the queen while the other half is given frames of eggs and young larvae. Bees will make a new queen.

C. Controlled Queen Rearing: The easiest way to rear queens is to move the queen from a strong, populous hive during a time when there is plenty of food coming into the hive, and provide the hive with a frame of eggs from a selected colony. You may have to remove all uncapped brood from this hive in order for the bees to make queen cells from the frame you supply them with; otherwise the bees will make queens from any available larvae.

L.P. # 7

You can have this hive continuously rear queen cells (called a Cell Builder) by removing mature, capped queen cells, adding frames of capped brood and feeding this hive. After you remove the mature queen cells, add a new frame of selected eggs.

Disadvantages:

- time consuming (cutting cells, adding brood)
- bees could select the bees desirable larvae
- bees could make poor queens

There are many other methods of queen rearing. They are much more complicated for beginner beekeepers or bee breeders. Those methods are described in a book called QUEEN REARING by H. M. Laidlaw, Jr. and J. E. Eckert; University of California Press, Berkeley, Cal., 1974.

D. Other factors in Rearing Queens

1. Queen Mating Yard: Once the mature queen cells are removed, they can be put into a small nucleus hive consisting of young bees, comb and plenty of food. These mating nucs should be placed in an area where there are many drones, drones from hives of good characteristics.
2. Starting Nucleus: Once the queen has emerged from the cell and starts to lay in the mating hive, she can be removed to a small hive, consisting of two to four frames of young bees and food. Once she starts to lay in this nuc, her performance and other desirable characteristics can be assessed before she is used to start a new hive.

LESSON PLAN # 8

MARKETING HIVE PRODUCTS

Time: 1½ hours

Materials: Demonstration, Display

Objectives: Help beekeepers to sell bee products,
and form cooperatives.

I. Honey

1. Harvesting

- honey is generally taken off when over 3/4ths of the comb is capped; uncapped honey tends to ferment since it is 'un-ripened' (i.e. not enough water has been evaporated off).
- combs can be cut out and pressed to extract honey and put into a screen or cloth bag, or scraped off to the midrib, leaving a foundation in the frame for the bees to start building again, or the wax tops can be cut off with a hot knife and the frame put into an extractor which will spin the honey off, leaving the comb intact. If cutting out comb, leave a 1 inch strip for bees to start on.
- once honey has been removed, strain the honey again through a finer cloth, to removed any particles, bees, debris, and dirt. Combs with brood should not be harvested.
- store honey in a shady but dry place, free from ants and other predators. Do not spray honey with insecticides. Bottle honey in any clear glass container, and label each bottle with quantity, usually by weight, and name of your yard. Honey is usually graded by color, the lighter the color the higher the grade. Some countries prefer darker honey and may be willing to pay more for it. Honey stored in the sun or in humid places will be ruined.
- honey in the wax comb can also be sold, either wrapped in plastic clear wrap, or bottled with honey

L.P. # 8

-if honey is too liquid, it will foam and ferment on the top. Such honey will spoil. Thick, clean honey, properly cured and stored (not in a damp place) will last many years. In time all honey will 'set up' or crystallize. This is not the same as spoiling and in fact many countries prefer this crystallized form.

2. Marketing

-all honey should be carefully labeled. Here is an example of a honey label.

ERIO APIARIES

net: 450 Grams

Palapala, Dasmariñas, Cavite

March, 1978

-stores, stands, individuals, commercial centers, baking industries, health foods stores, etc. are interested in selling honey. Individual contacts can be made or through a buyer, especially in the larger towns and cities.

II. Wax

1. How to process and harvest

-all beeswax should be kept, scrapings from the hive, left over from wax moth infestation, and what is harvested with the honey. Wax in many countries is more valuable than honey. Here's

L.P. # 8

how to harvest beeswax:

:Place wax in tub or pot and cover with water. The pot should be sturdy and not likely to break when put over the fire. Water should not boil over, as wax is very flammable and could burn easily. The wax will rise to the top and, once melted, strain it through a wire screen or jute sack cloth. The pail the wax is cooled in should have a larger top than bottom for easy removal of wax cake. Scrape away debris on bottom once cake is hard.

A solar wax molter can be constructed using a heavy wooden box with a heavy glass top. Place in the sun, the wax inside will melt quickly. If a tin tray is made with a collecting spout, and a can placed under the spout, the melted wax will melt and be in a convenient cake in one step.

2. Marketing wax

-Wax can be used in the following ways:

- :cosmetics
- :machine tooling
- :sailing outfits
- :leather processing
- :wood polish
- :candles

-attached are copies of waterproofing, leather preparation and wax polish you can make and sell, as well as how to make wax candles.

III. Pollination/ selling bees

1. Leasing hives

--soon, growers in this country will see the value of having bees pollinate their fruits and vegetables. While experimental still in this country, growers will be willing to rent hives for beekeepers to move in while the crop is blooming and remove after flowering is done, or the grower has to spray insecticides.

L.P. # 8

2. Selling bees and equipment

The following things can be sold to beginners and advanced beekeepers alike:

- :wooden parts (frames, boxes, tops, bottom, etc.)
- :swarms
- :improved queens
- :wax comb or foundation
- :smokers, veils, hive tool
- :wax melters
- :beeswax candle kits

IV. Beekeeping Cooperatives

1. Beekeeping cooperatives could be helpful for small time beekeepers in the following ways:

- able to sell more honey, combining resources to make labels, bottle honey, etc.
- organize leasing of hives through growers known in the area
- making equipment and selling it cooperatively
- exchanging information and sending representatives to periodic workshops, seminars, or courses
- able to combine resources to buy and share books periodicals or other literature

2. Ways that cooperatives can raise money are:

- membership dues
- service charge for any seminars held by coop
- selling equipment, honey, wax etc.
- renting fees for pollination services
- commercial apiaries or university (or other private) contributions
- sale of goods made with honey etc. (baked goods, honey wine candles).

3. Eventually, some goals that can be realized by cooperative are:

- improving strains of bees (native)
- standardizes equipment built and used (sold)

L.P. # 8

- develop individual technology and style for locality
- keep records of honey/pollen plants in area, for honey flow data
- become a service center for beekeepers in large area, providing equipment, foundation mills, extracting equipment, bottles and labeling needs.

Beeswax Recipes

LEATHER PREPARATION

1 part tallow

1 part neatsfoot oil (or other oil)

1 part beeswax

Melt oil over hot water, add clarified melted tallow and clarified wax cake: mix and cool. Cover tightly.

BEE SWAX POLISH

Melt 1 pound ($\frac{1}{2}$ kg.) of beeswax and stir in $2\frac{1}{2}$ of turpentine (mineral oil can also be added) until wax cools. Use as wood polish.

WATERPROOFING

4 oz. wax

4 oz. resin

1 pint linseed oil

$\frac{1}{4}$ pint turpentine

Melt wax and resin, stir in oil and cool while adding turpentine. Rub into leather.

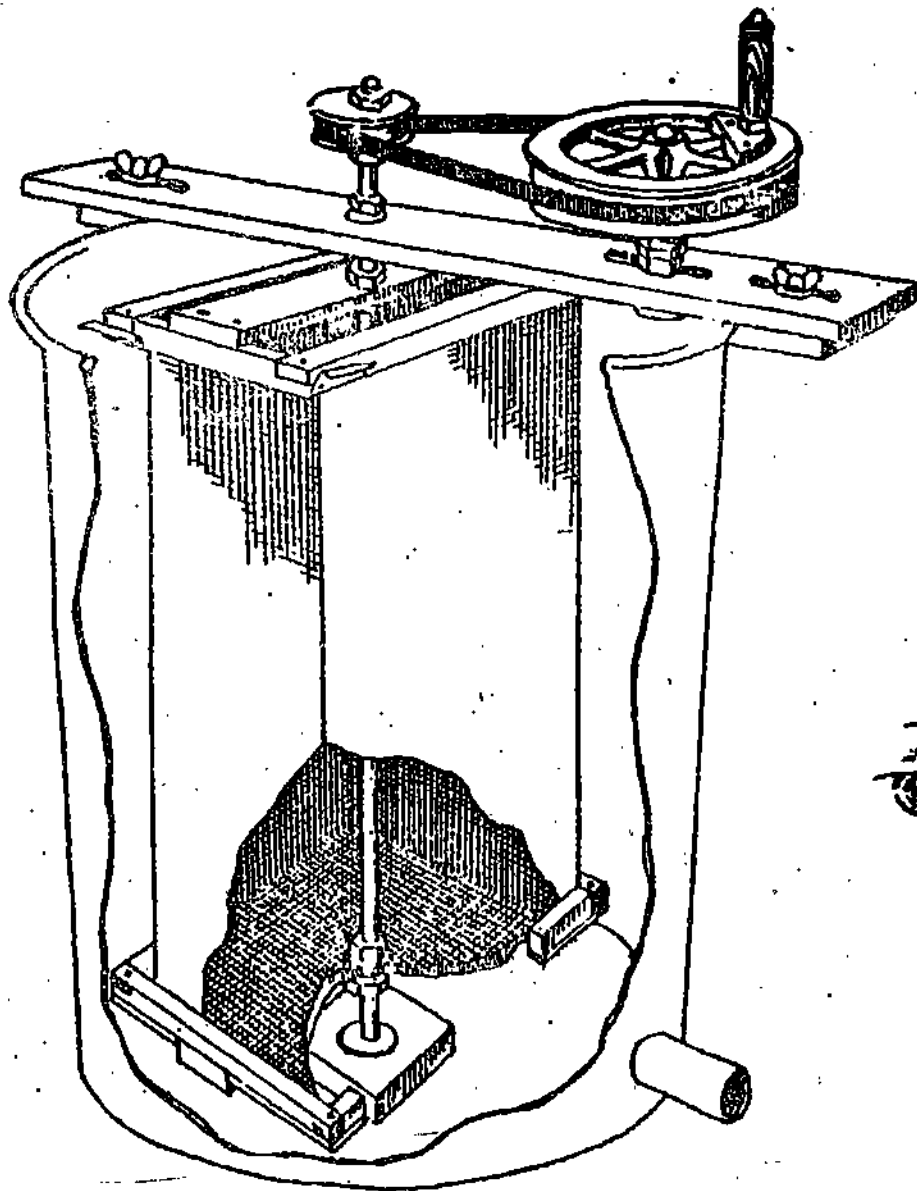

51

HONEY EXTRACTOR

Illustration #36

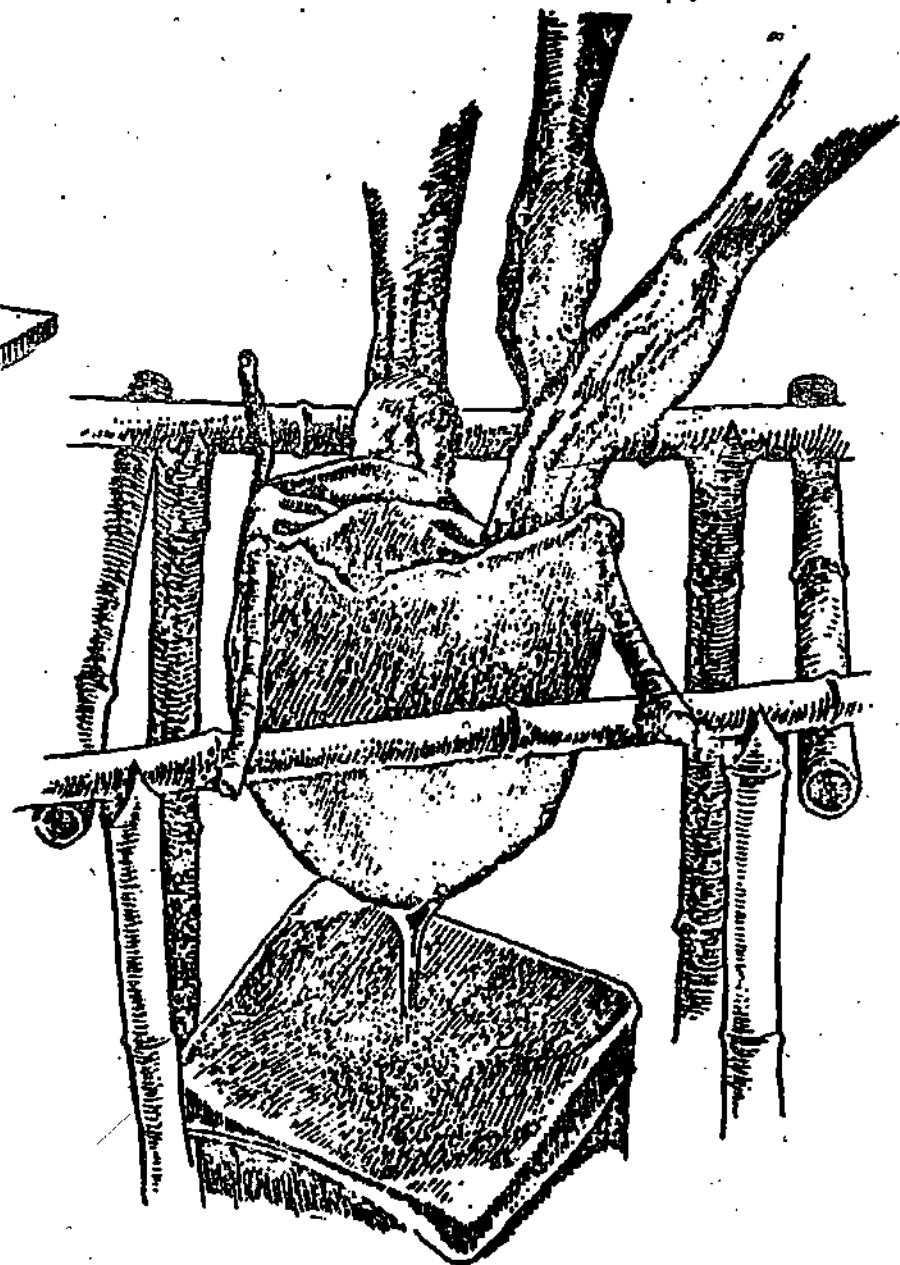

52

SQUEEZING OUT HONEY
Illustration #37

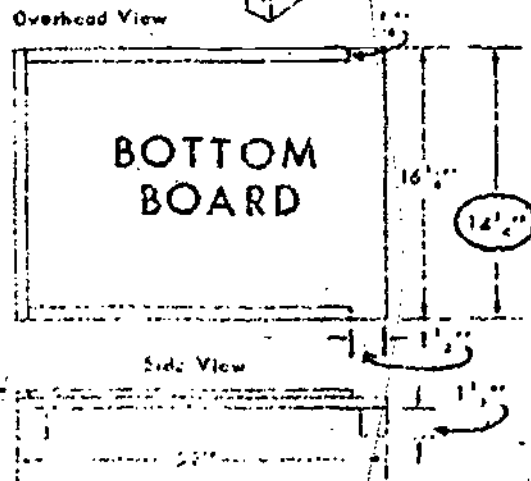
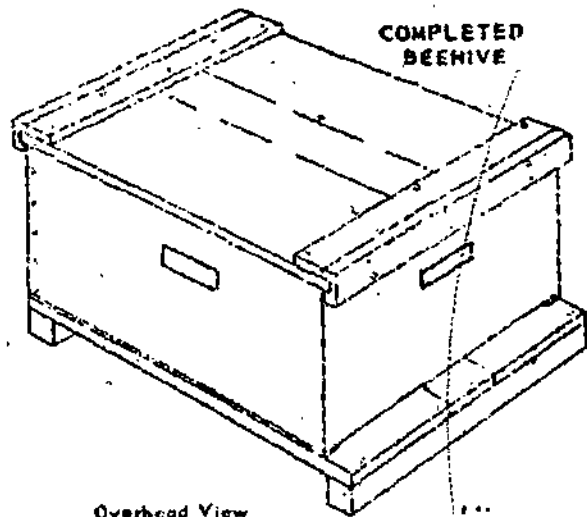
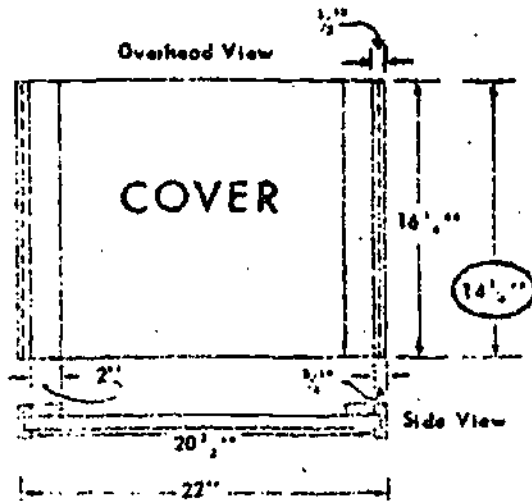
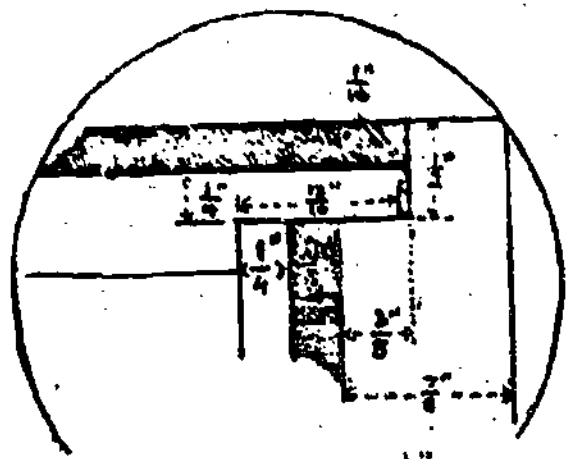
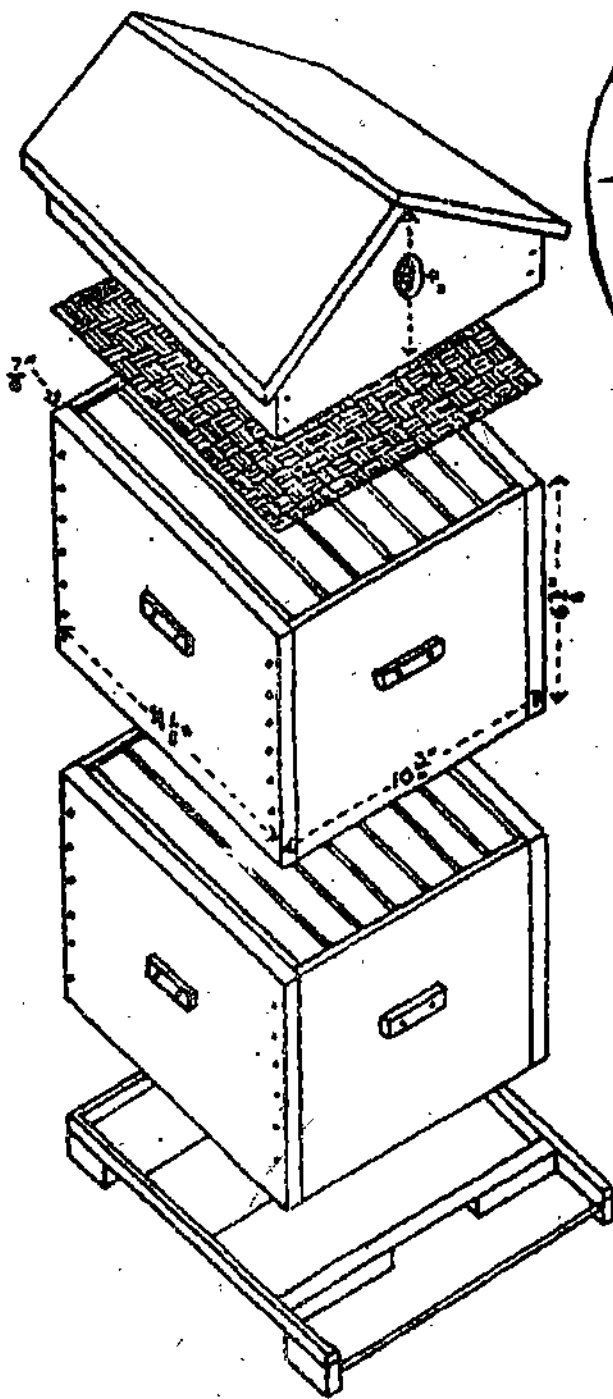

NEWTON BEEHIVE

Illustration #15

SCALE $\frac{1}{4}'' = 1''$

DEEP BRUOD SUPER

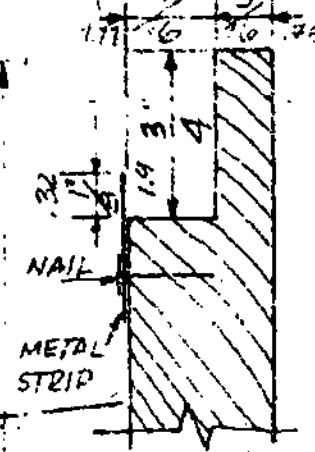
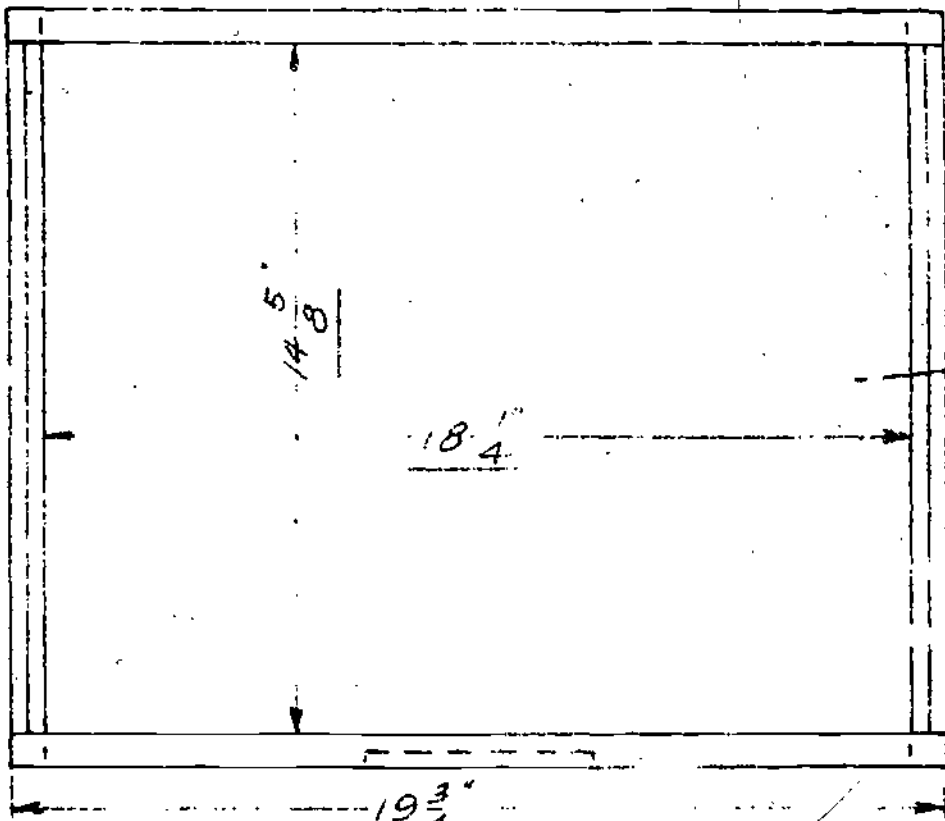

FULL SIZE CROSS-SECTION OF ENDS

$\frac{3}{4} \times \frac{3}{8}$ D.P. DADO

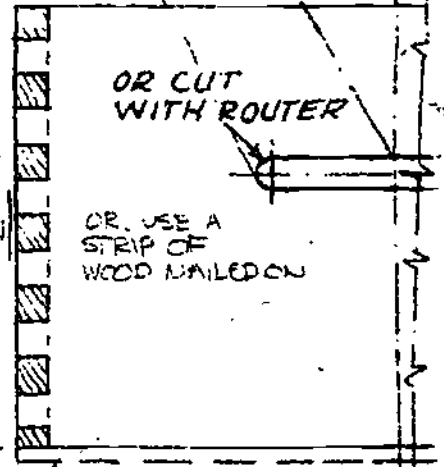
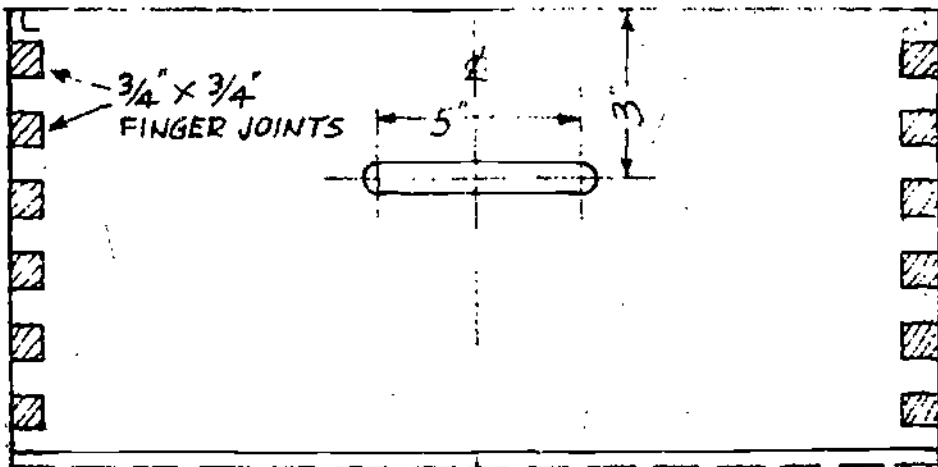
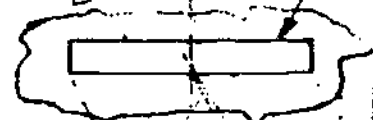

TRIM TO 9 $\frac{1}{2}$ AFTER MAKING JOINTS IF NECESSARY.

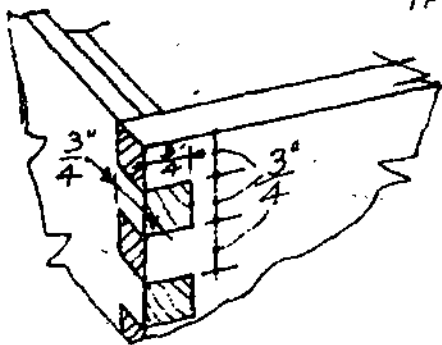

MITER GAUGE

$\frac{3}{4} \times \frac{3}{4}$ BLOCK

$\frac{3}{4}$

SHALLOW SUPER

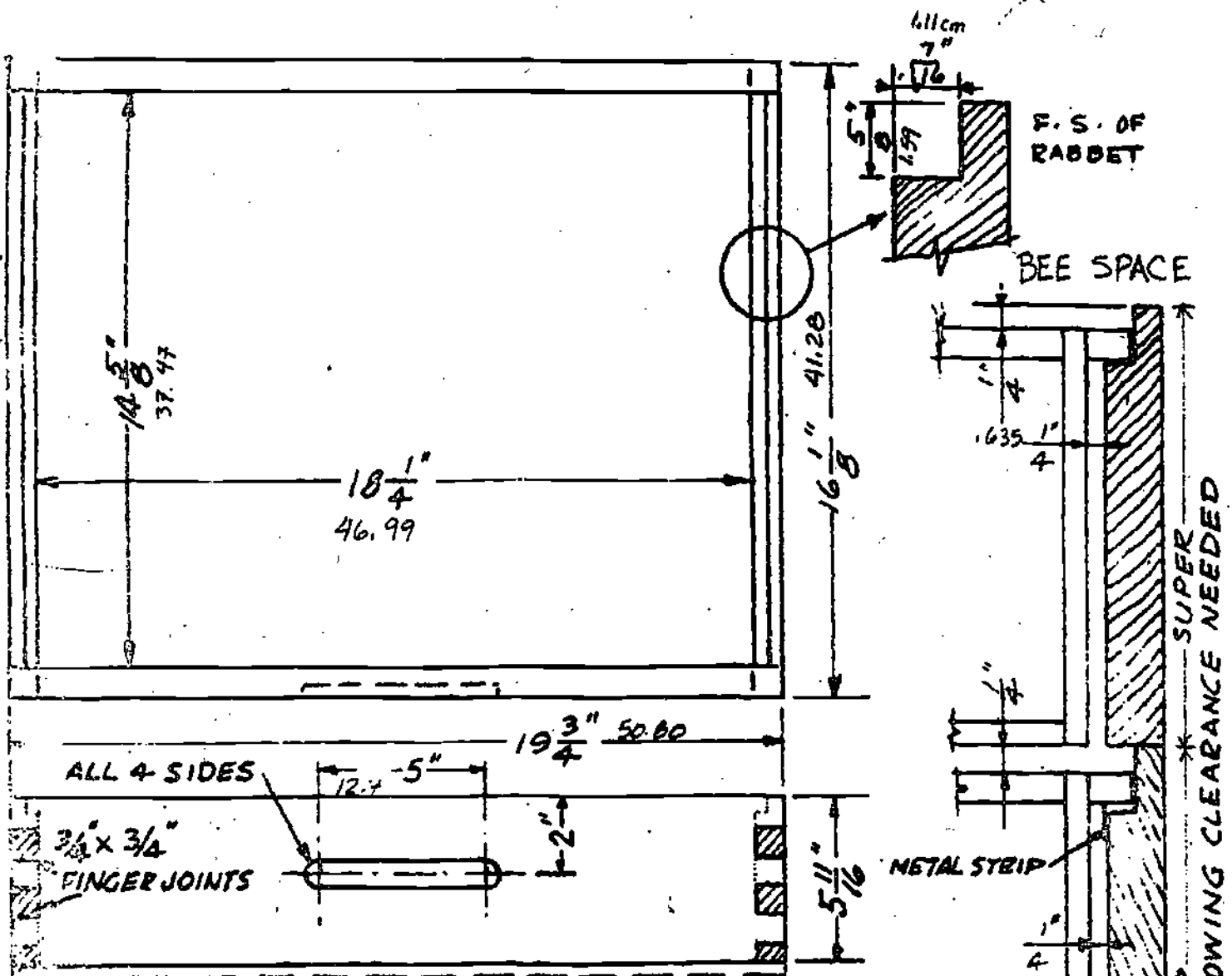

ROUGH CUT 6" TRIM AFTER MAKING JOINTS

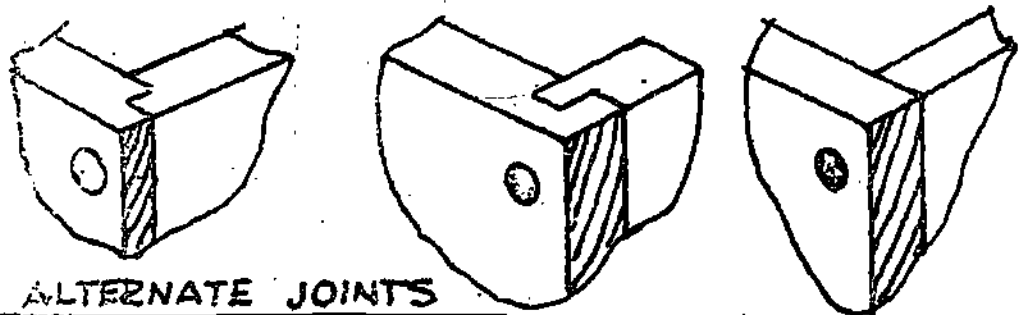

ALTERNATE JOINTS
GLUE & NAIL

NOTE: WHEN ASSEMBLING THE brood chamber, be sure to nail the rabbeted area as shown in the sketch at right with two very thin wire nails. The thin section on the rabbeted ends gets a lot of hard usage, and will be reinforced this way to keep it from breaking.

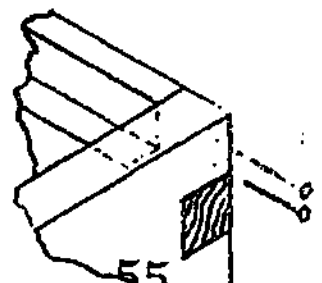

55
BEST COPY AVAILABLE

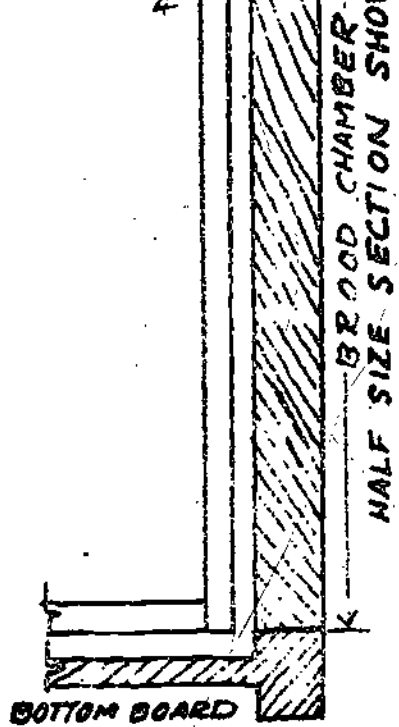

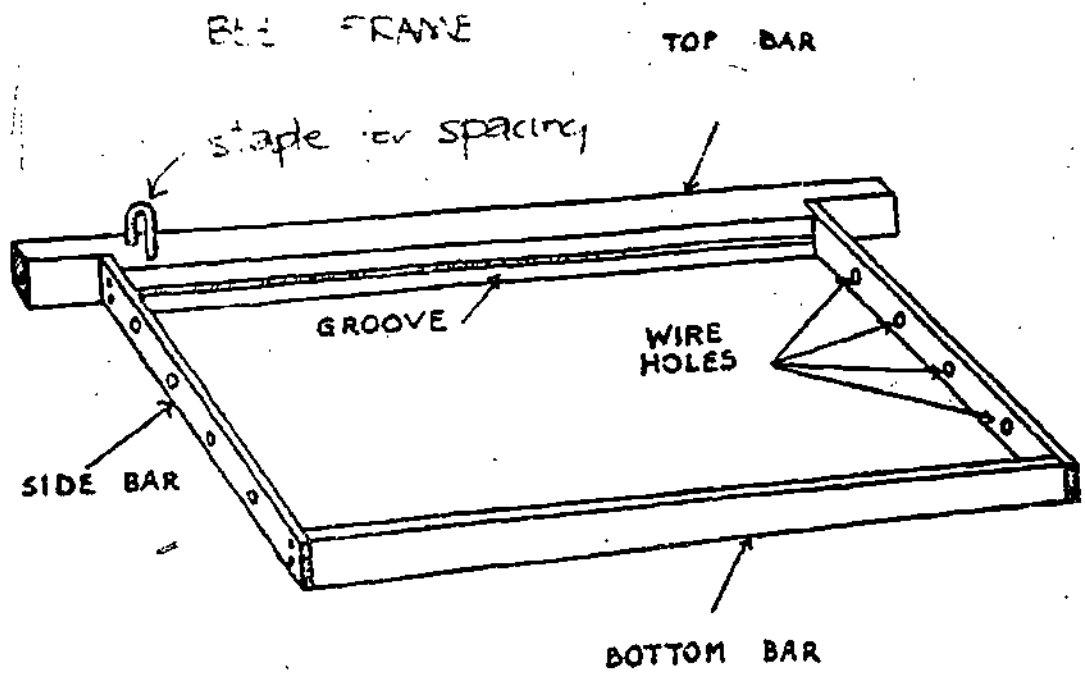
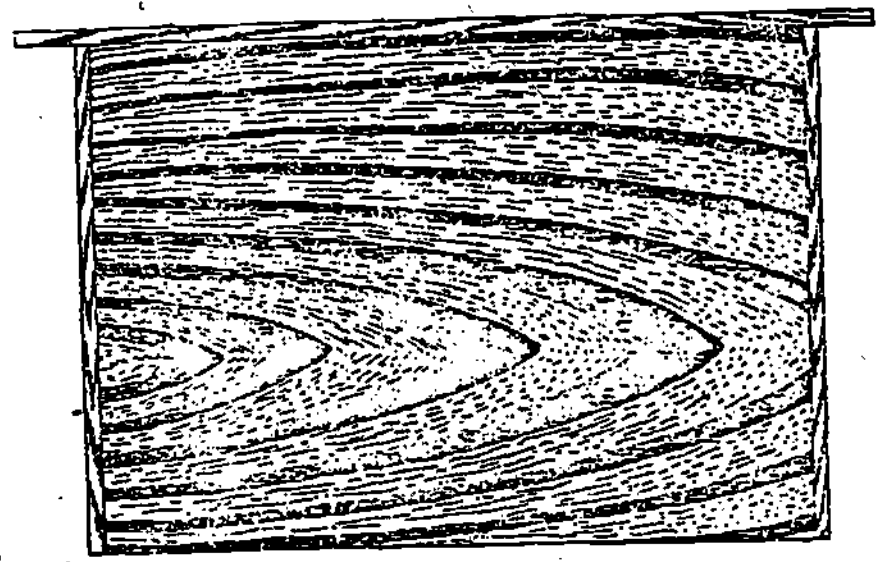

Illustration #2



FOLLOWER OR DIVISION BOARD

Illustration #3

56

FRAMES

Levent

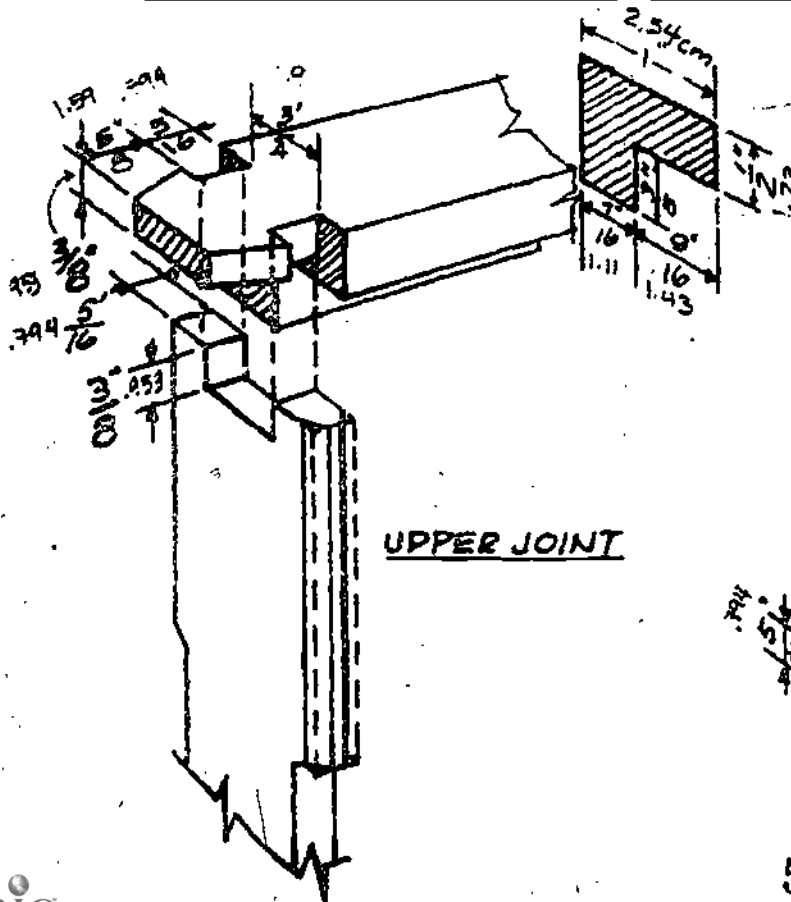
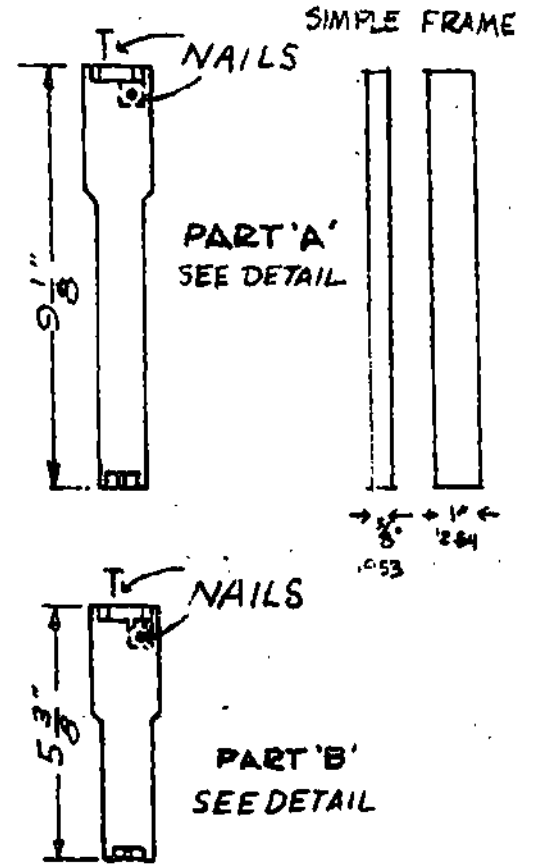
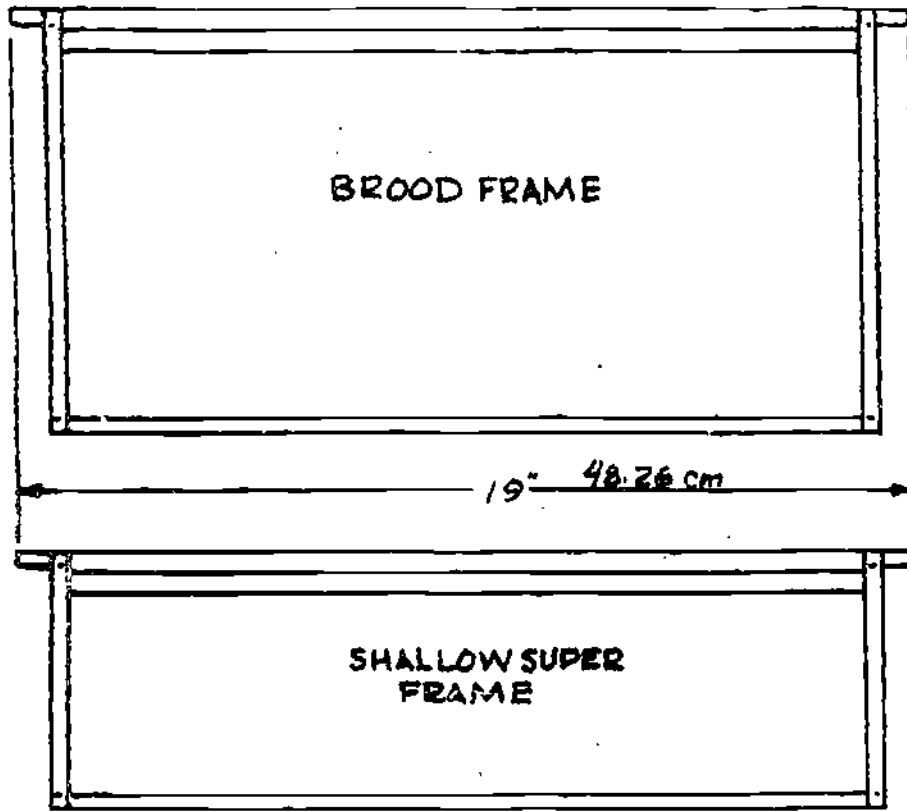

FRAME DEPTH TO SUPER DEPTH

9 1/8" (23.32)	=	9 5/8" (24.59)
6 1/4" (15.88)	=	6 3/8" (16.83)
5 3/8" (13.65)	=	5 1/16" (14.45)
4 1/2" (11.43)	=	4 1/8" (11.75)

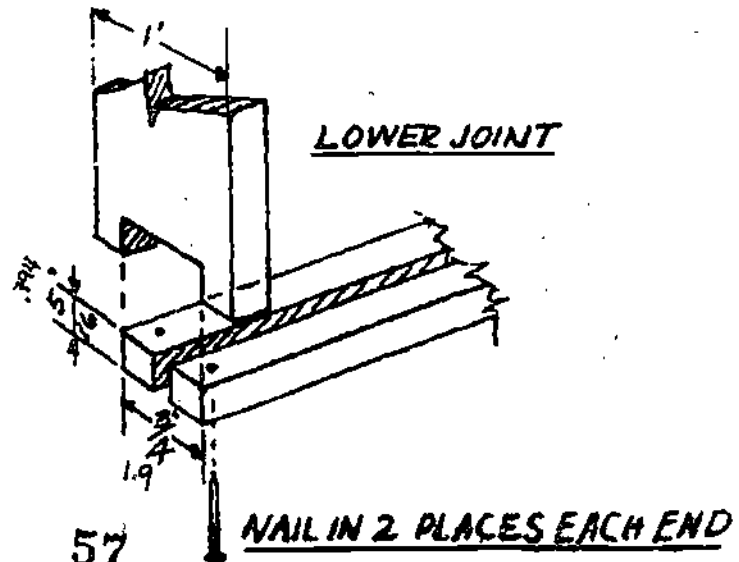

FULL SIZE PATTERNS

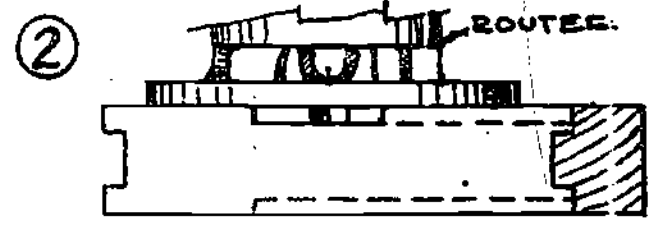
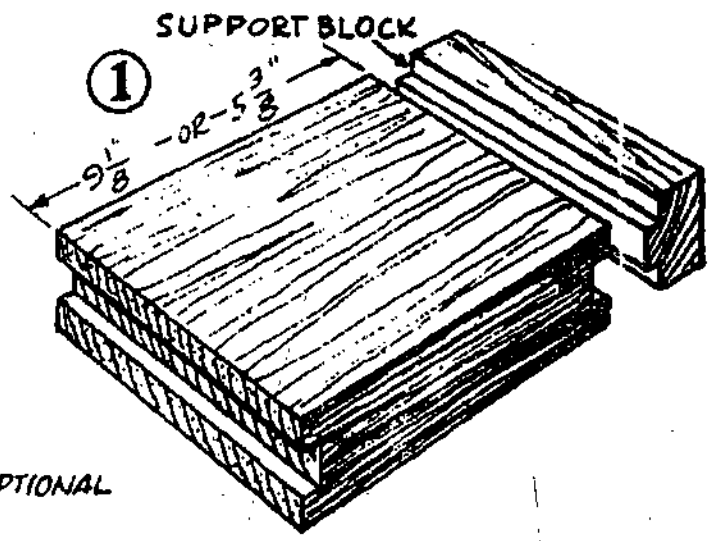
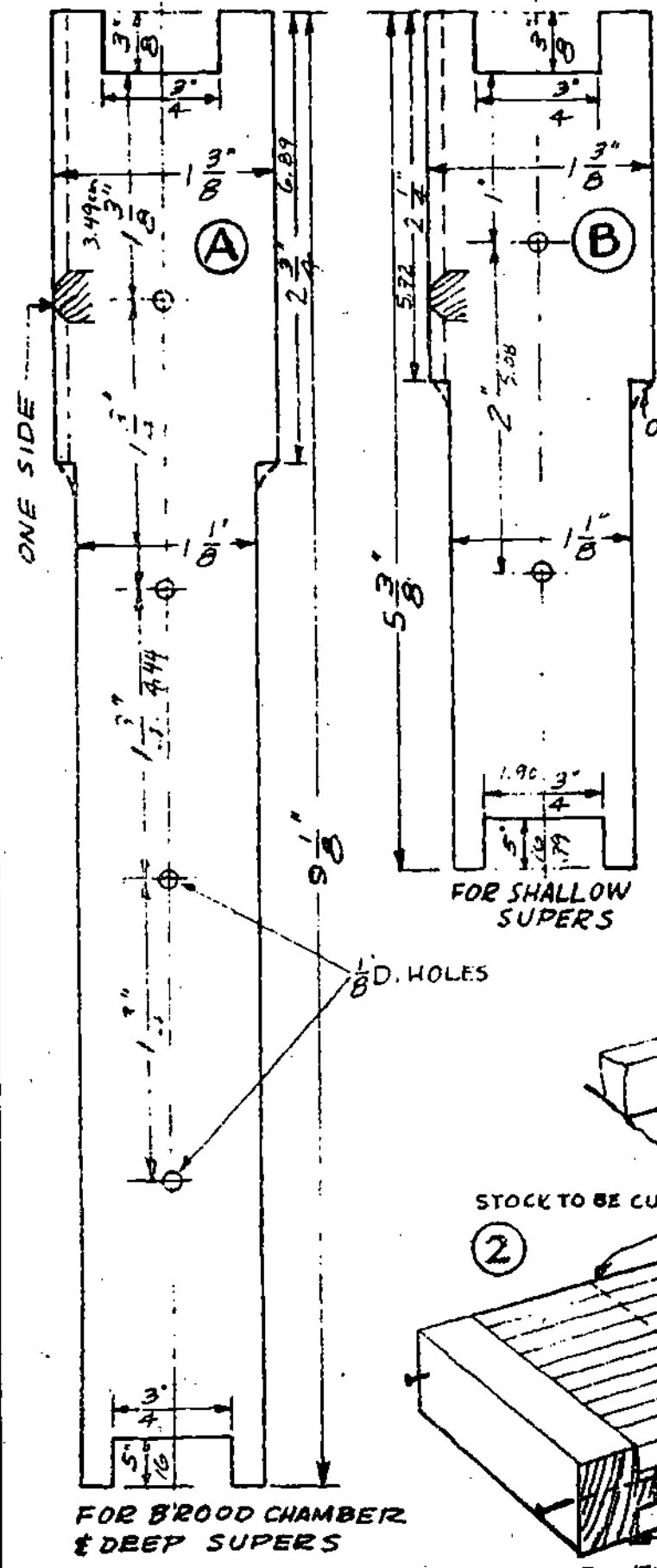

OR USE DADO SAW.

③ SLICE TO $\frac{5}{16}$ " THICK

ALT. RIP TO $\frac{5}{16}$ " THICK. CUT TO LENGTH.

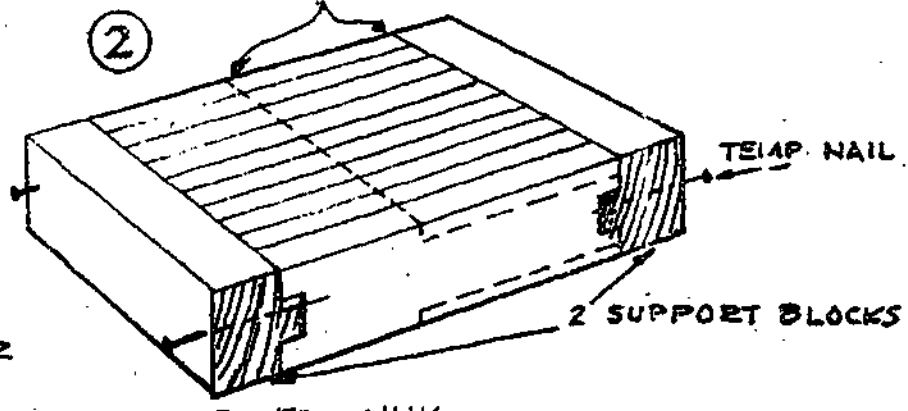
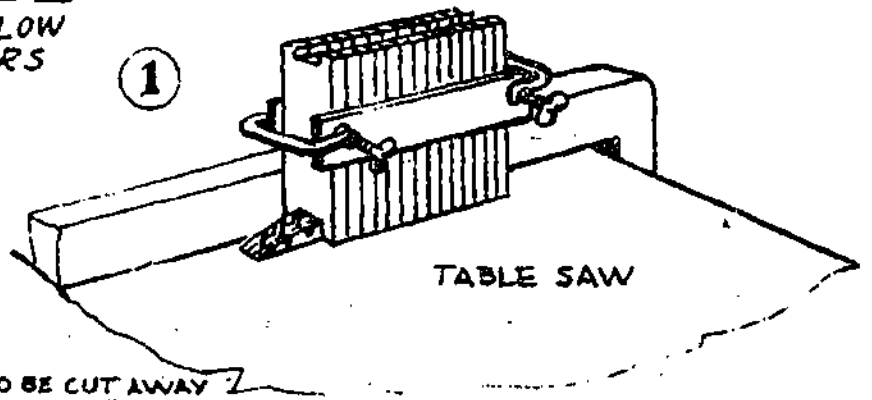

MADE WITH POWER SAWS

FRAME - TOP & BOTTOM

Sam

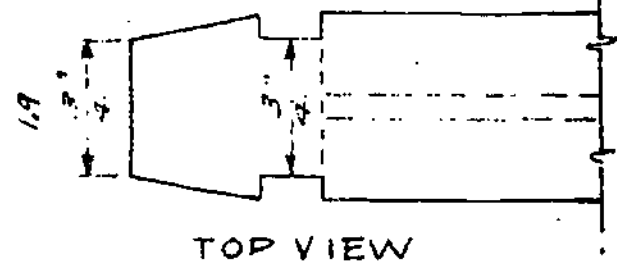
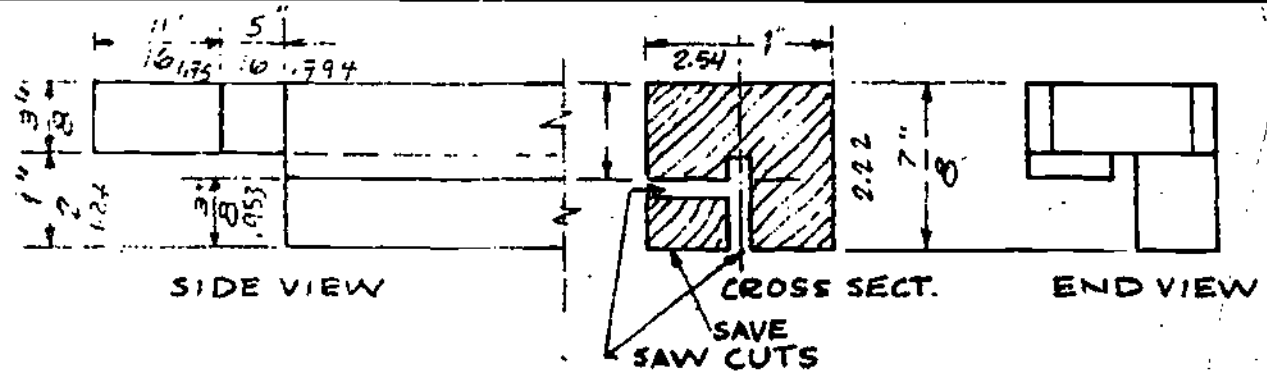
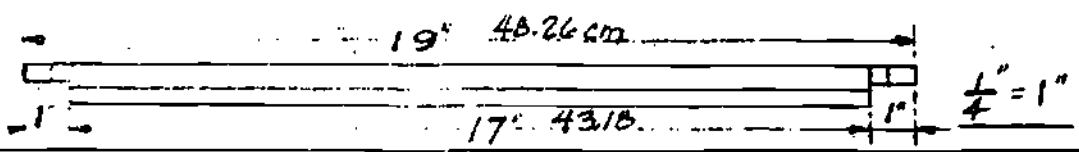

FULL SIZE DETAIL
FRAME TOP

FRAME BOTTOM

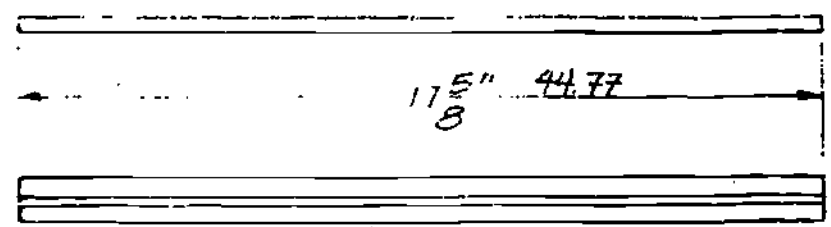

LEAVE THIN WEB

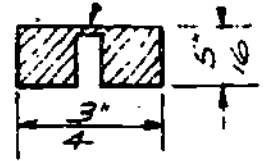

CROSS SECTION
FULL SIZE

1/4" = 1"

OPTIONAL FRAME SPACER (BEE SPACE)

Staple or metal clip

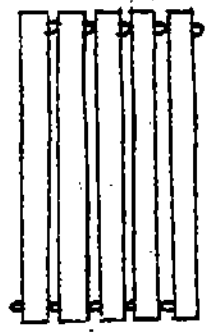
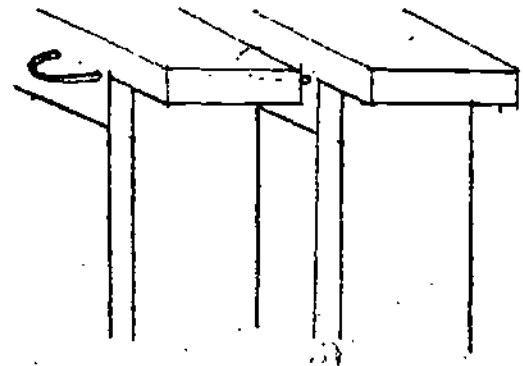

PROPER SPACING
IN SIMPLE FRAME
FOR A. INDICA
BEE SPACE IS
1/8 - 3/16" (3.17 - 4.76mm)
FOR A. MELLER
B.S. 1/4 - 3/8" (6.3 - 9.5mm)

BEE FRAME FOR APIS INDICA CEPHALA

OUTSIDE BOX DIMENSIONS SHOULD REFLECT NEE SIZES, REMEMBER THE BEE SPACE.

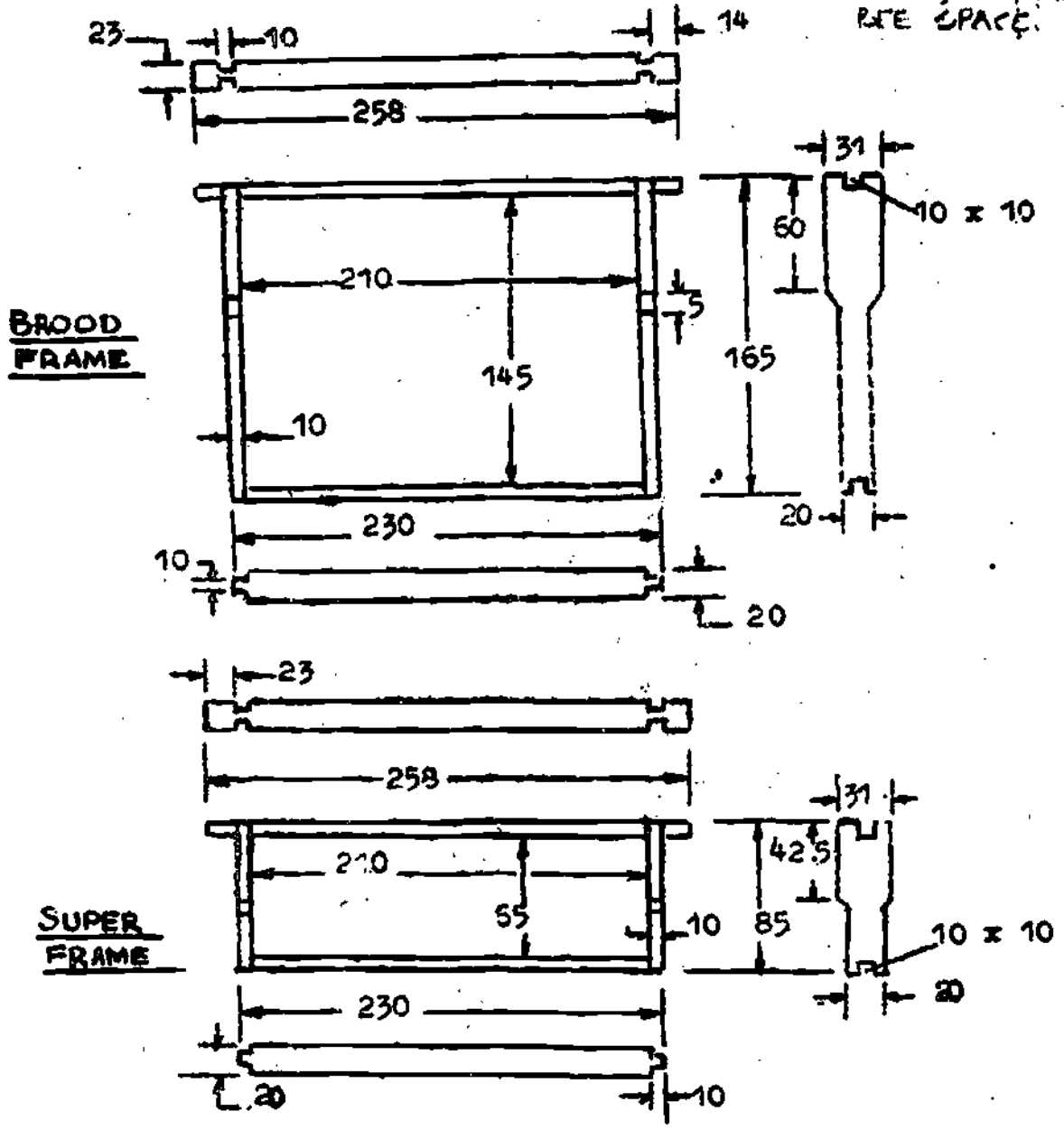

(All dimensions in millimetres)

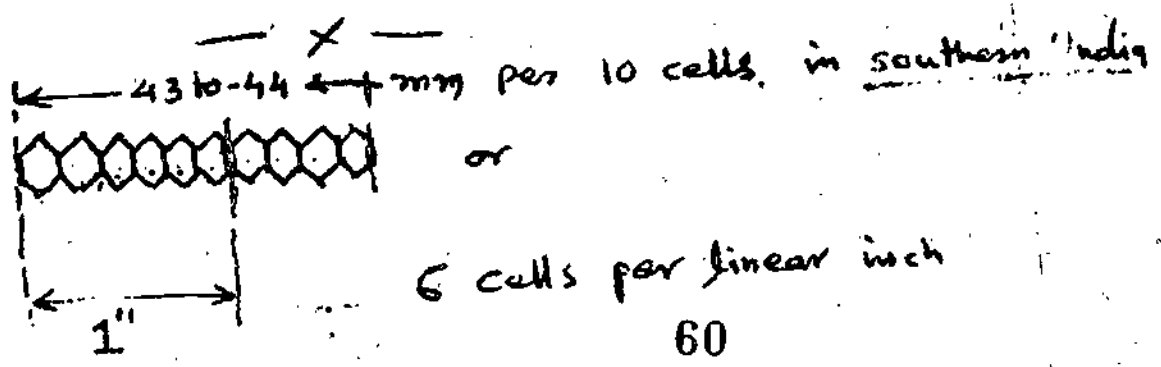

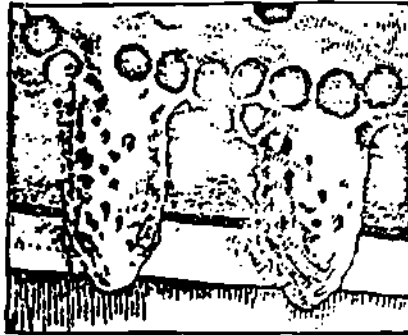

QUEEN CELLS

Illustration #4



DRONE CELL

Illustration #5

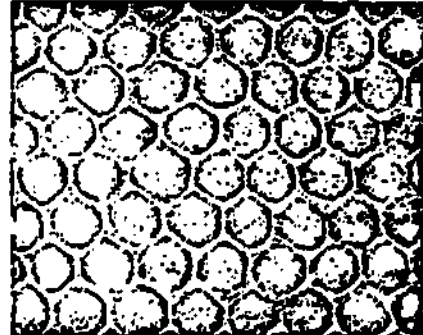

WORKER CELLS

Illustration #6

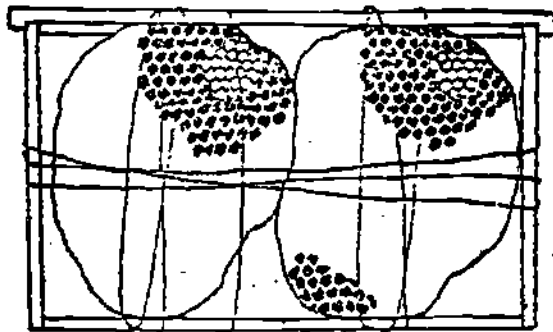

TYING OLD. COMB TO A FRAME

Illustration #7.

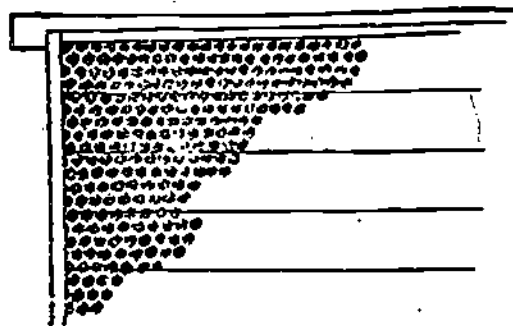

SHEET OF FOUNDATION WAX

Illustration #8

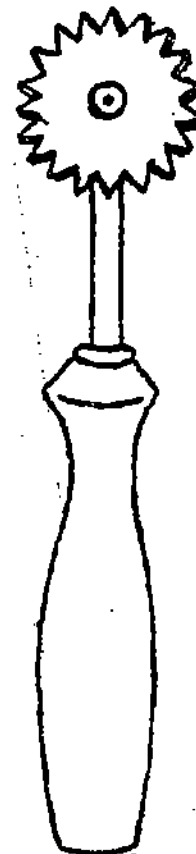

SPUR WIRE-EMBEDDER

Illustration #9

Amund

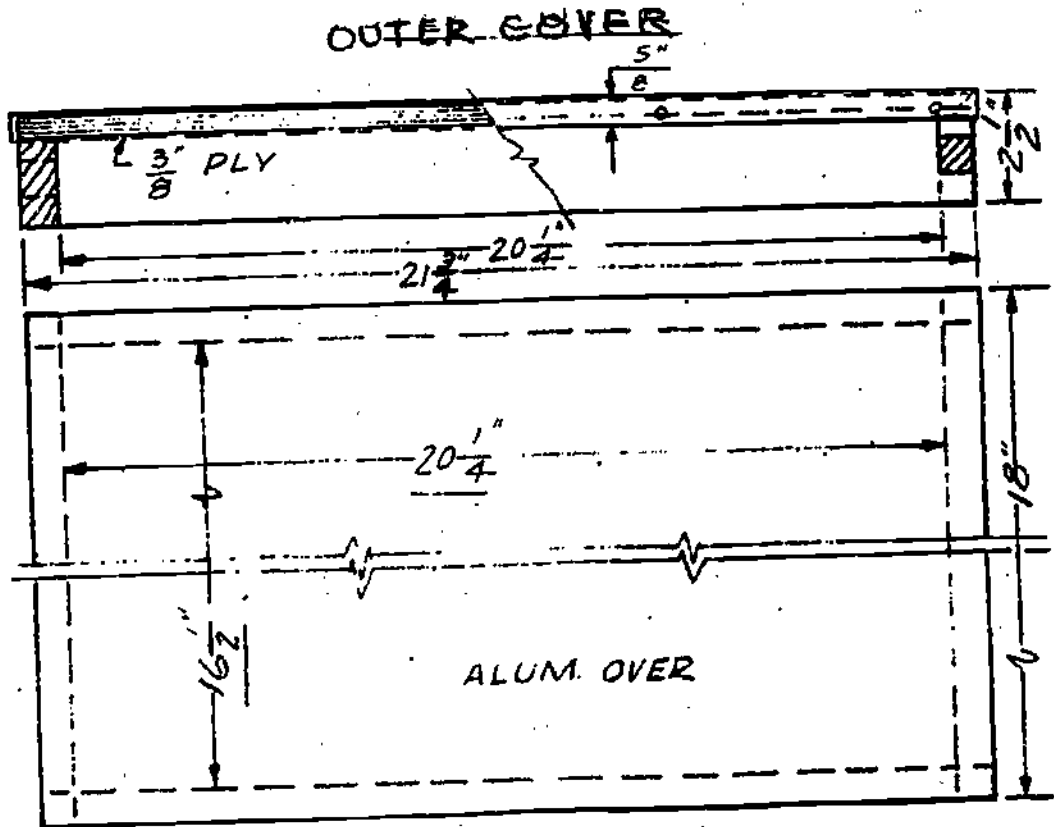

SEE OPTIONAL OUTER COVERS

INNER COVER not always needed; wood strips, fiber mat or jute sack cloth

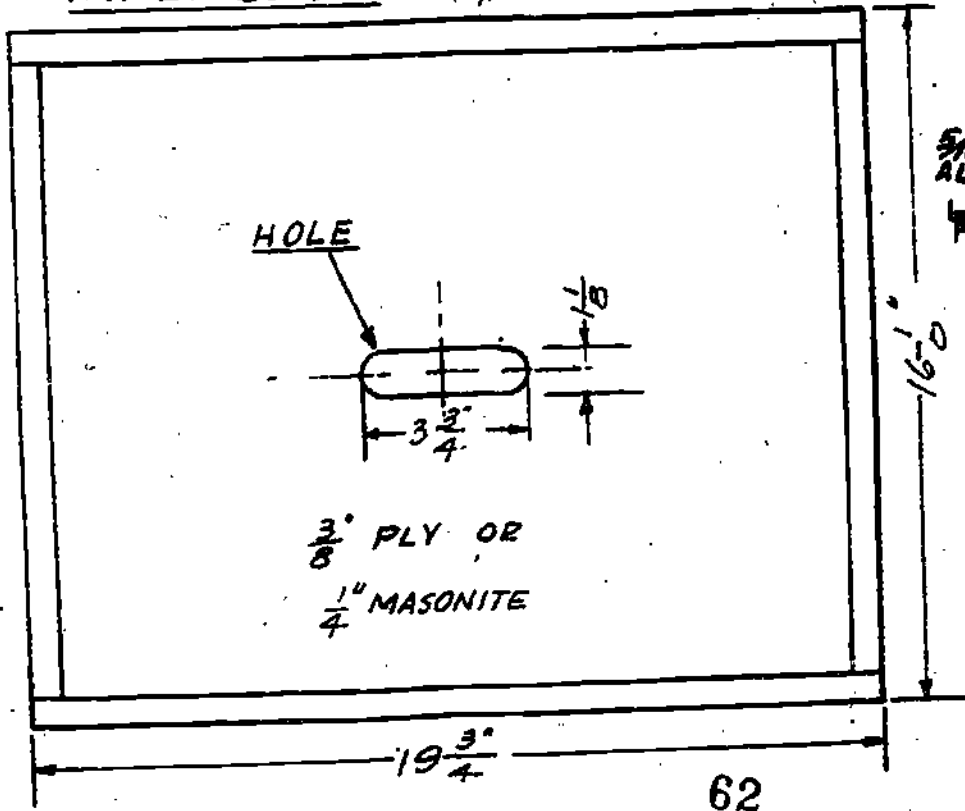

$\frac{5}{16} \times \frac{3}{16}$
ALL EDGES

62

BOTTOM BOARD

Diagram

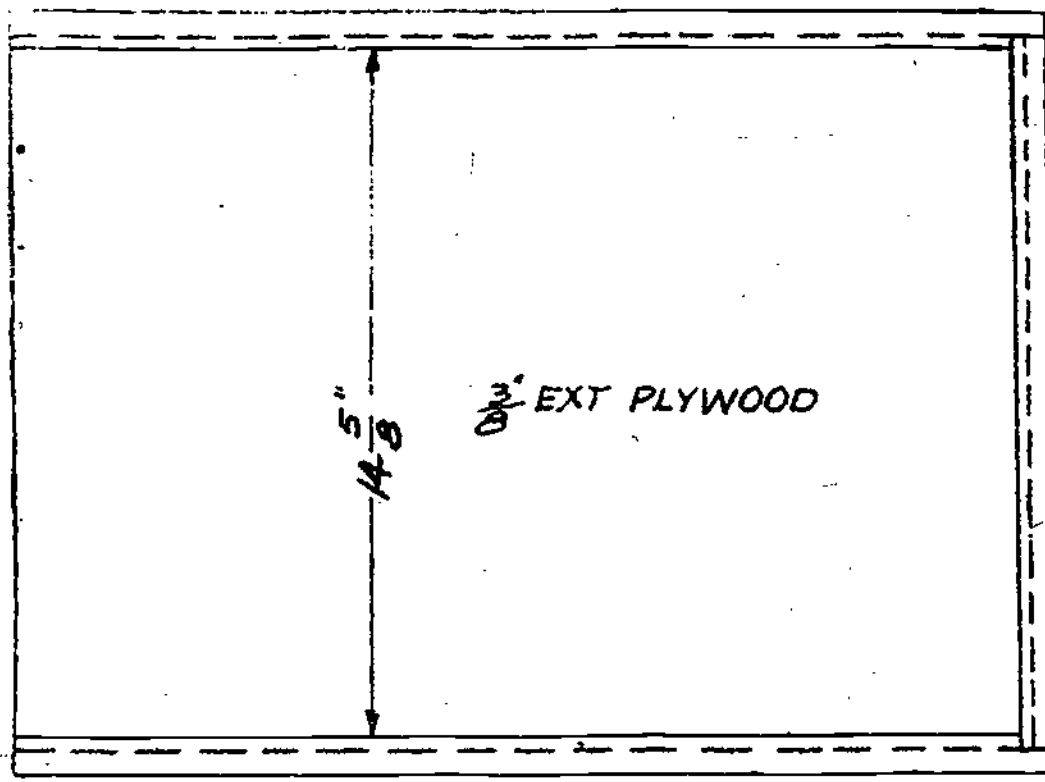

TOTAL L. $16\frac{1}{4}$ " (41.26cm)

JOINT AT CORNERS

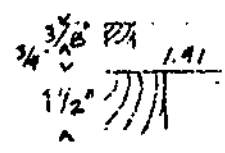
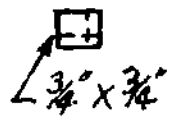
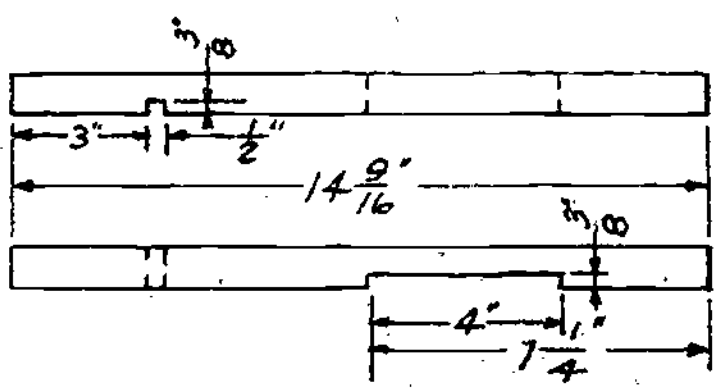
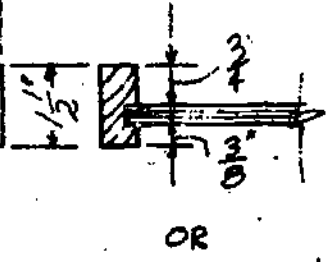
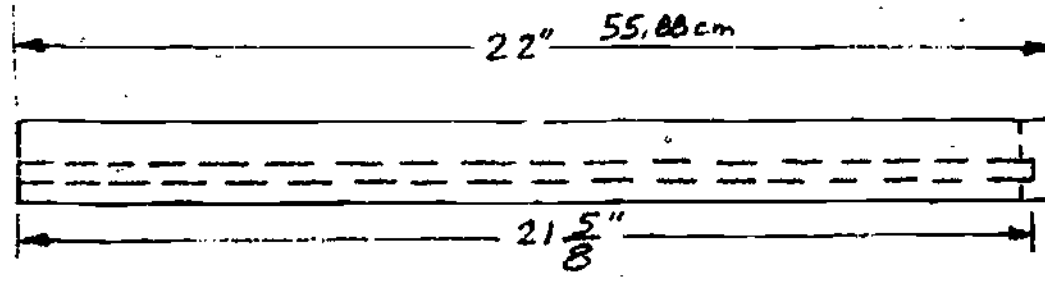
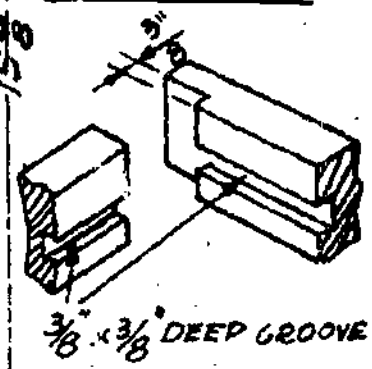

ENTRANCE REDUCER

A. indica should have smaller entrance hole.

SMOKER

Small

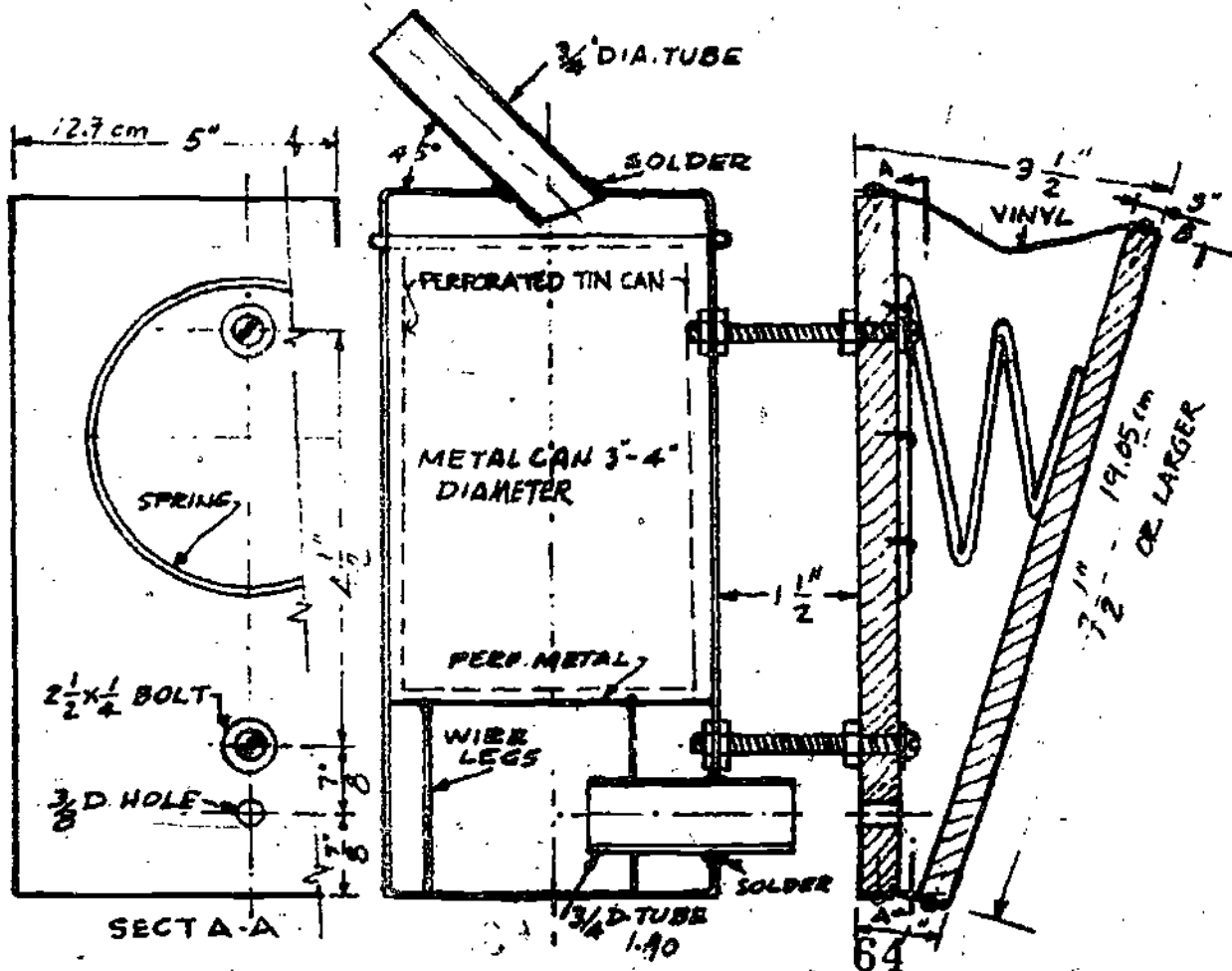
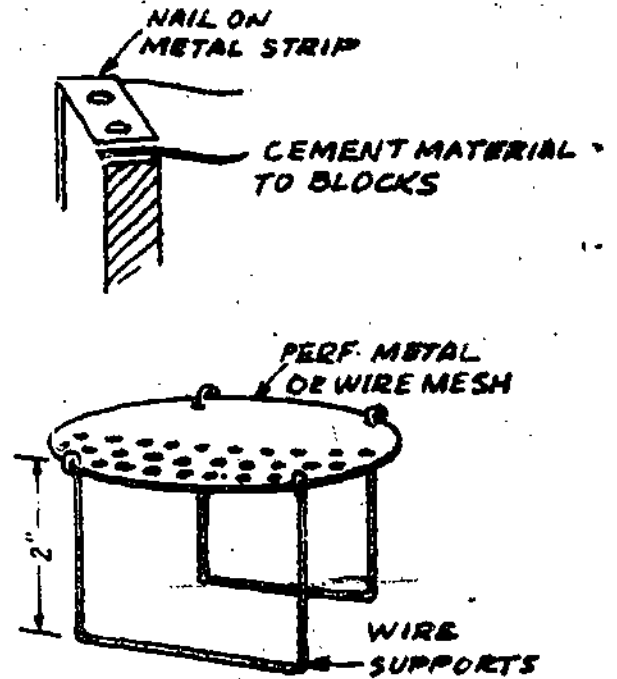
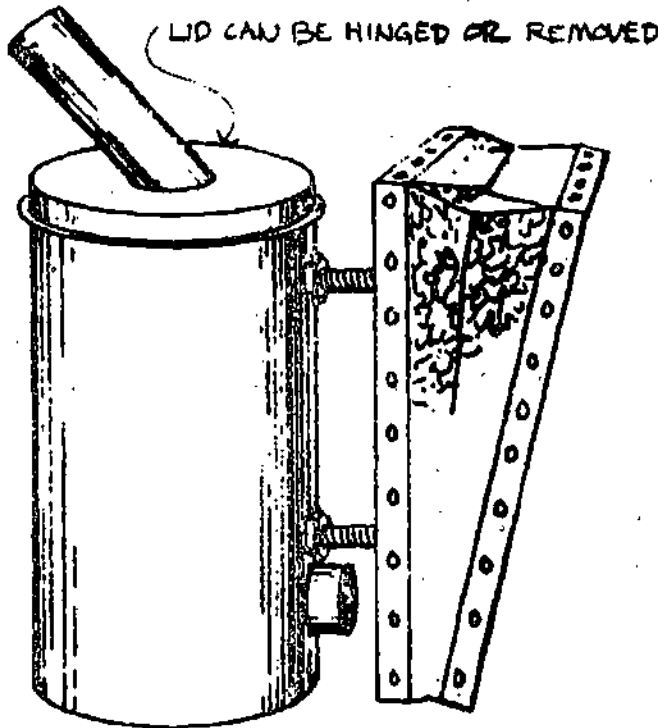

VEIL

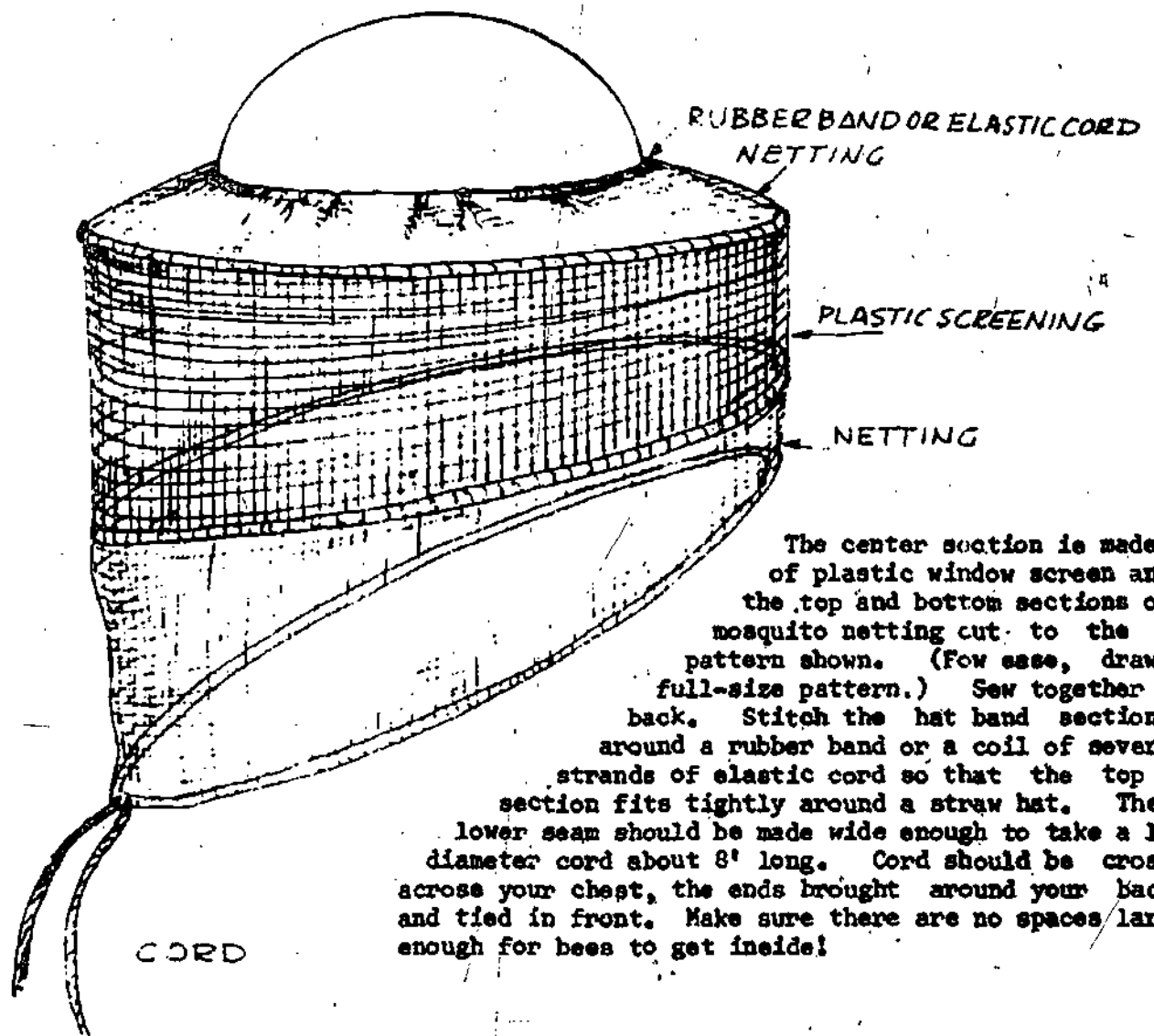

The center section is made of plastic window screen and the top and bottom sections of mosquito netting cut to the pattern shown. (For ease, draw full-size pattern.) Sew together in back. Stitch the hat band section around a rubber band or a coil of several strands of elastic cord so that the top section fits tightly around a straw hat. The lower seam should be made wide enough to take a 1/8" diameter cord about 8' long. Cord should be crossed across your chest, the ends brought around your back and tied in front. Make sure there are no spaces large enough for bees to get inside!

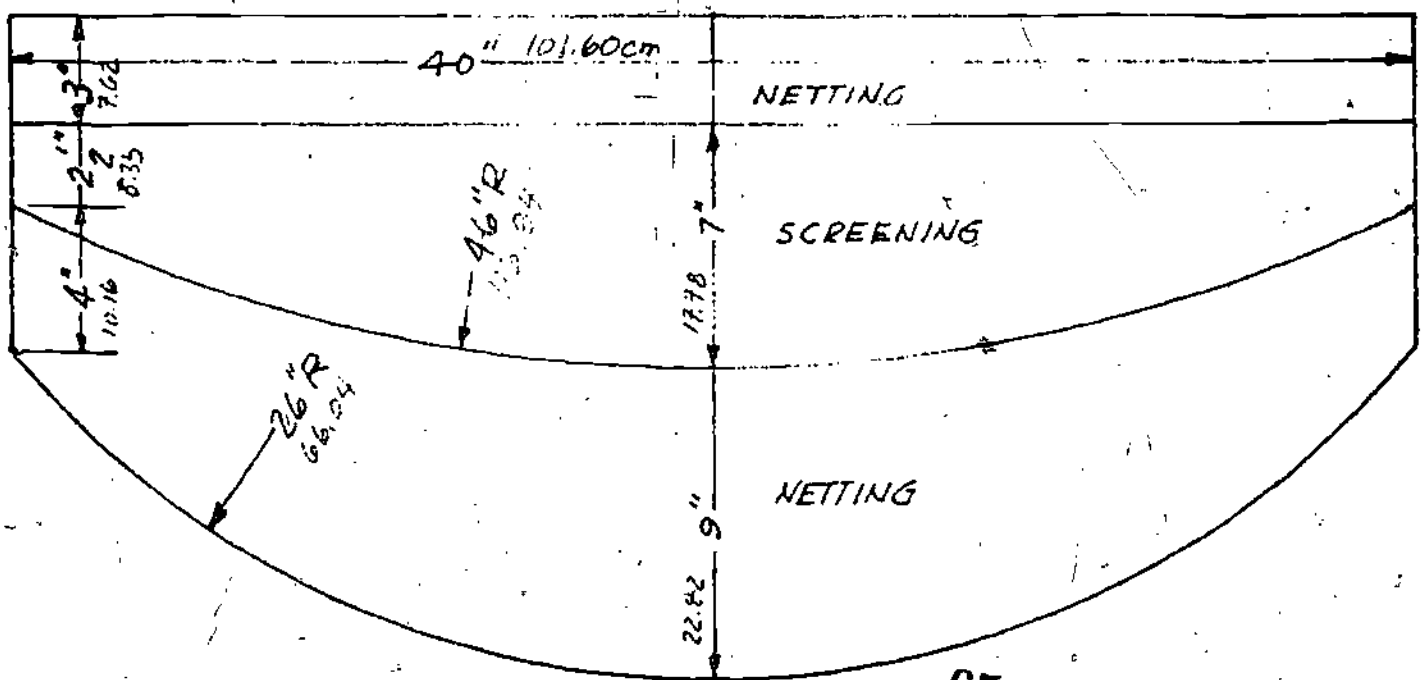

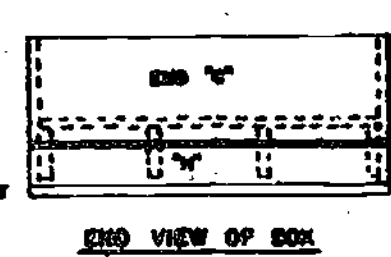
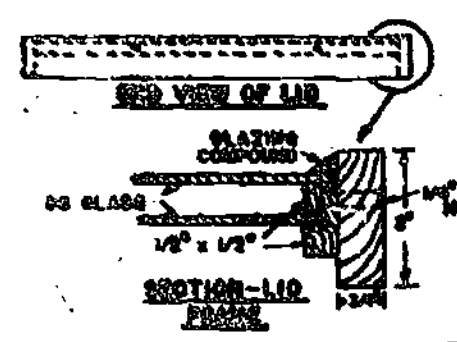
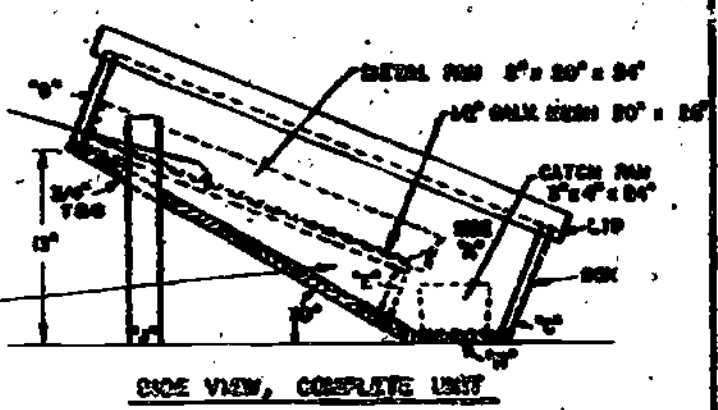
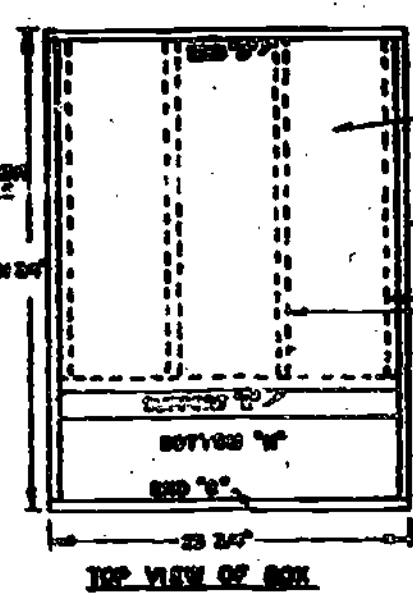
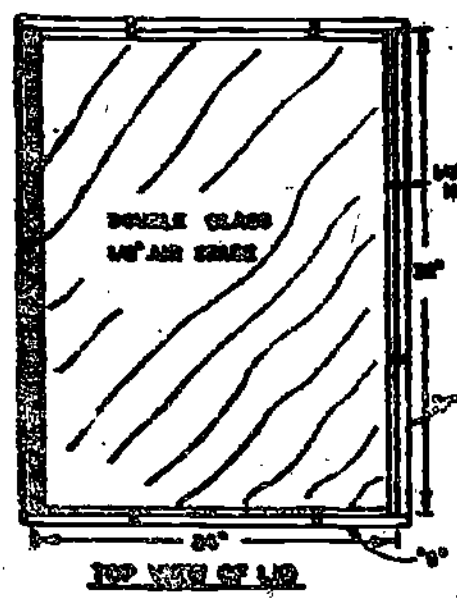

- NOTES**
1. PAINT INSIDE WHITE.
 2. PAINT OUTSIDE BLACK.
 3. SEAL ALL CRACKS.
 4. PLACE IN PROTECTED PLACE ON SOUTH SIDE OF A BUILDING.
 5. REMOVE WAX AND HONEY WHEN BEET CRABS ARE BELTED. THE HONEY SHOULD BE DISCARDED.
 6. SEE REVERSE SIDE FOR BILL OF MATERIALS.

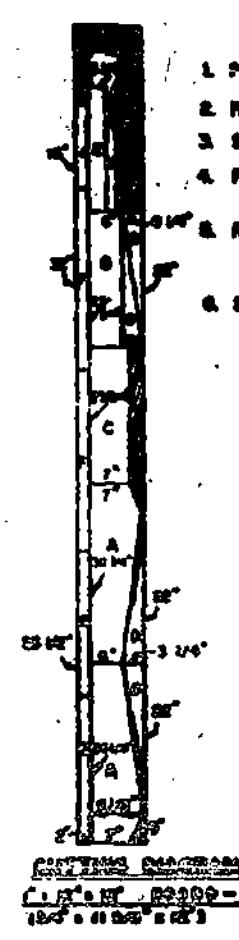
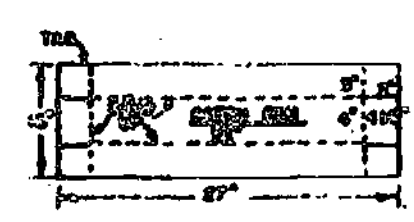
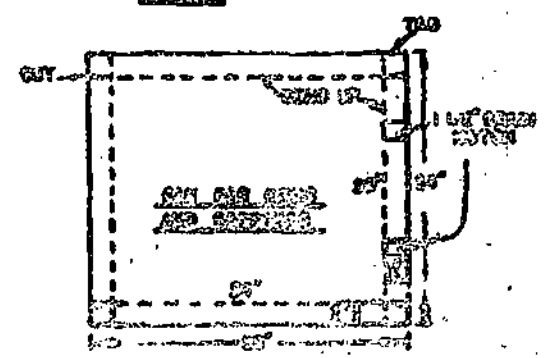

THE PENNSYLVANIA STATE UNIVERSITY AGRICULTURAL EXTENSION SERVICE		
SOLAR BEEBEEK EXTRACTOR		
DESK. OF. EXT. DESIGN 1, 2000 DATE: 8/1/50	CREED ER 700-020	SHEET 1 OF 1

REFERENCES USED

1. Apiculture in Tropical Climates. ed. E. Crane, I.B.R.A., London, Great Britain, 1976.
2. The Beekeeper's Handbook. D. Sammataro and A. Avitabile. Peach Mt. Press, Dexter, Mich. 1978.
3. Beekeeping. F. Vernon. Hodder and Stoughton. Aylesbury, Bucks. Great Britain. 1976.
4. A Beekeeping Guide. H.H. Attfield. VITA. Tech. Bull. \$9, Bucks, Rainer, Mrd. 20822, U.S.A.
5. Beekeeping in the Philippines. R.A. Mores, and F.M. Laigo. Farm Bulletin #27. Un. of Philippines, Los Banos, 1968.
6. Beekeeping in the Tropics. F.G. Smith: Western Printing Services, Ltd. Bristol, Great Britain, 1960.
7. Central Bee Research Institute. Technical Bulletins. 3 Isla Road, Vile Parle (West). Bombay, India. 400056.
8. The Hive and the Honey Bee. ed. Dadant & Sons, Hamilton, Illinois, 1975.
9. Insect Pollination of Cultivated Crop Plants. S.E. McGregor. Ag. Handbook #496. U.S.D.A., Washington, D.C. 1976.
10. Practical Beekeeping. Tompkins and Griffith. Garden Way Publ. Charlotte, Vt. 05445, 1977.
11. Queen Breeding for Amateurs. C.P. Abbott. Bee Craft, : Bracken Dene. Manor Way, Petts Wood, Kent. Great Britain, 1951.
12. Queen Rearing. H. Laidlaw, and J.E. Eckert. Un. of California Press Berkeley, 1962.

note: most of the drawings in the Lesson Plans were from A Bee-keeping Guide.

3

Since 1961 when the Peace Corps was created, more than 80,000 U.S. citizens have served as Volunteers in developing countries, living and working among the people of the Third World as colleagues and co-workers. Today 6000 PCVs are involved in programs designed to help strengthen local capacity to address such fundamental concerns as food production, water supply, energy development, nutrition and health education and reforestation.

Loret Miller Ruppe, Director
 Everett Alvarez, Jr. Deputy Director
 Richard B. Abell, Director, Office of Programming and Training Coordination.

Peace Corps overseas offices:

<u>BELIZE</u> P.O. Box 487 Belize City	<u>FIJI</u> P.O. Box 1094 Suva	<u>MALAYSIA</u> 177 Jalan Raja Muda Kuala Lumpur	<u>SEYCHELLES</u> Box 564 Victoria
<u>BENIN</u> BF 971 Cotonou	<u>GABON</u> BP 2098 Libreville	<u>MALI</u> BP 85 Bamako	<u>SIERRA LEONE</u> Private Mail Bag Freetown
<u>BOTSWANA</u> P.O. Box 93 Gaborone	<u>GAMBIA, The</u> P.O. Box 582 Banjul	<u>MAURITANIA</u> BP 222 Nouakchott	<u>SOLOMON ISLANDS</u> P.O. Box 547 Honiara
<u>CAMEROON</u> BP 817 Yaounde	<u>GHANA</u> P.O. Box 5796 Accra (North)	<u>MICRONESIA</u> P.O. Box 336 Saipan, Mariana Islands	<u>SWAZILAND</u> P.O. Box 362 Mbabane
<u>CENTRAL AFRICAN REPUBLIC</u> BP 1080 Bangui	<u>GUATEMALA</u> 6a Avenida 1-46 Zona 2 Guatemala	<u>MOROCCO</u> 1, Rue Benzerte Rabat	<u>TANZANIA</u> Box 9123 Dar es Salaam
<u>CHILE</u> Casilla 27-D Santiago	<u>HONDURAS</u> Apartado Postal C-51 Tegucigalpa	<u>NEPAL</u> P.O. Box 613 Kathmandu	<u>THAILAND</u> 42 Soi Somprasong 2 Petchburi Road Bangkok 4
<u>COSTA RICA</u> Apartado Postal 1266 San Jose	<u>JAMAICA</u> 9 Musgrove Avenue Kingston 10	<u>NIGER</u> BP 10537 Niamey	<u>TOGO</u> BP 3194 Lome
<u>DOMINICAN REPUBLIC</u> Apartado Postal 1414 Santo Domingo	<u>KENYA</u> P.O. Box 30518 Nairobi	<u>OMAN</u> P.O. Box 966 Muscat	<u>TONGA</u> BP 147 Nuku'Alofa
<u>EASTERN CARRIBBEAN</u> Including: Antigua Barbados, Grenada, Montserrat, St. Kitts-Nevis, St. Lucia, St. Vincent, Dominica "Erin Court" Bishops Court Hill P.O. Box 696-C Bridgetown, Barbados	<u>LESOTHO</u> P.O. Box 554 Maseru	<u>PAPUA NEW GUINEA</u> c/o American Embassy Port Moresby	<u>TUNISIA</u> 8, Ave. Louis Braille Tunis
<u>ECUADOR</u> Casilla 635-A Quito	<u>LIBERIA</u> Box 707 Monrovia	<u>PARAGUAY</u> c/o American Embassy Asuncion	<u>UPPER VOLTA</u> BP 537-Semandin Ouagadougou
	<u>MALAWI</u> Box 208 Lilongwe	<u>PHILIPPINES</u> P.O. Box 7013 Manila	<u>WESTERN SAMOA</u> P.O. Box 880 Apia
		<u>RWANDA</u> c/o American Embassy Kigali	<u>YEMEN</u> P.O. Box 1151 Sana'a
		<u>SENEGAL</u> BP 254 Dakar	<u>ZAIRE</u> BP 697 Kinshasa